



Deep Sequence Modeling

Ava Soleimany

MIT 6.S191

January 24, 2022

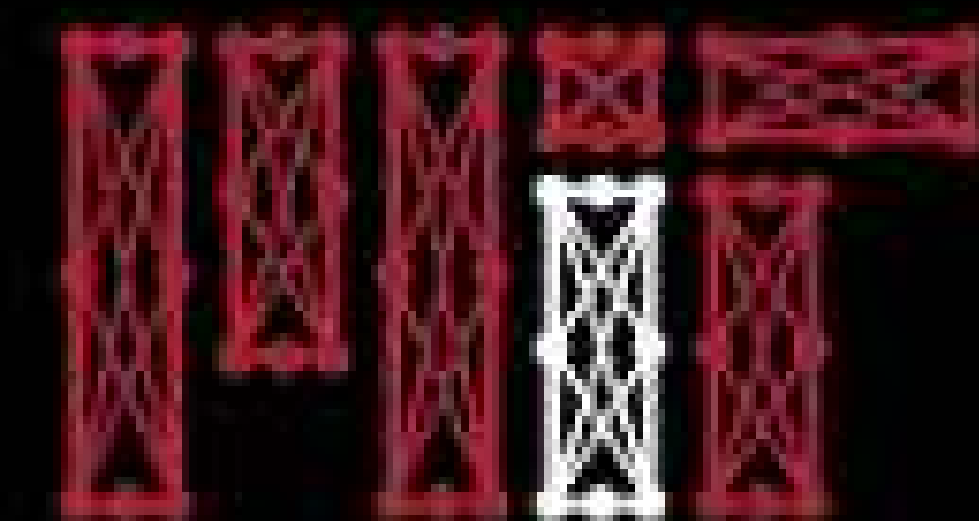

6.S191 Introduction to Deep Learning

introtodeeplearning.com [@MITDeepLearning](https://twitter.com/MITDeepLearning)



Given an image of a ball,
can you predict where it will go next?



Given an image of a ball,
can you predict where it will go next?

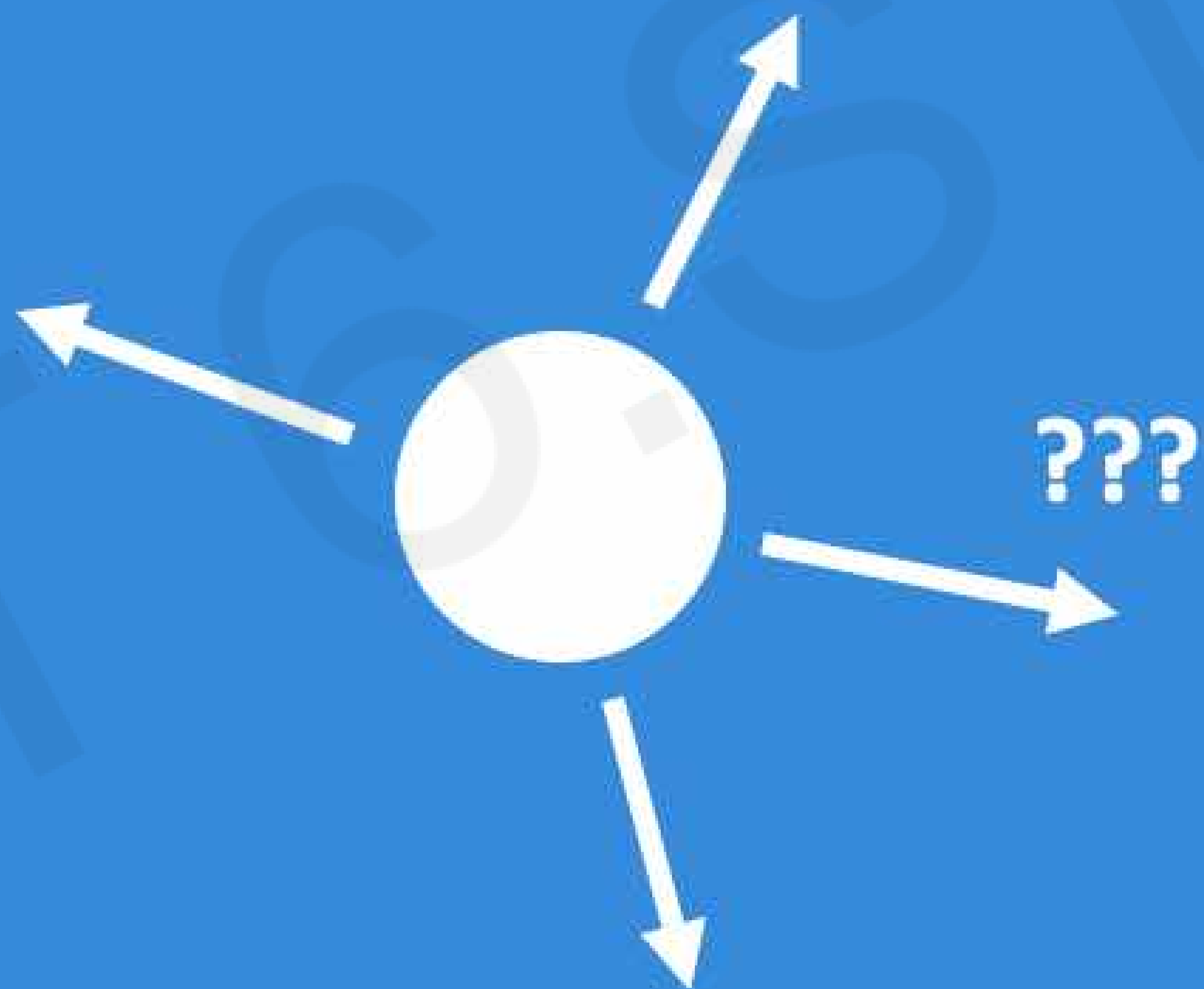

Given an image of a ball,
can you predict where it will go next?

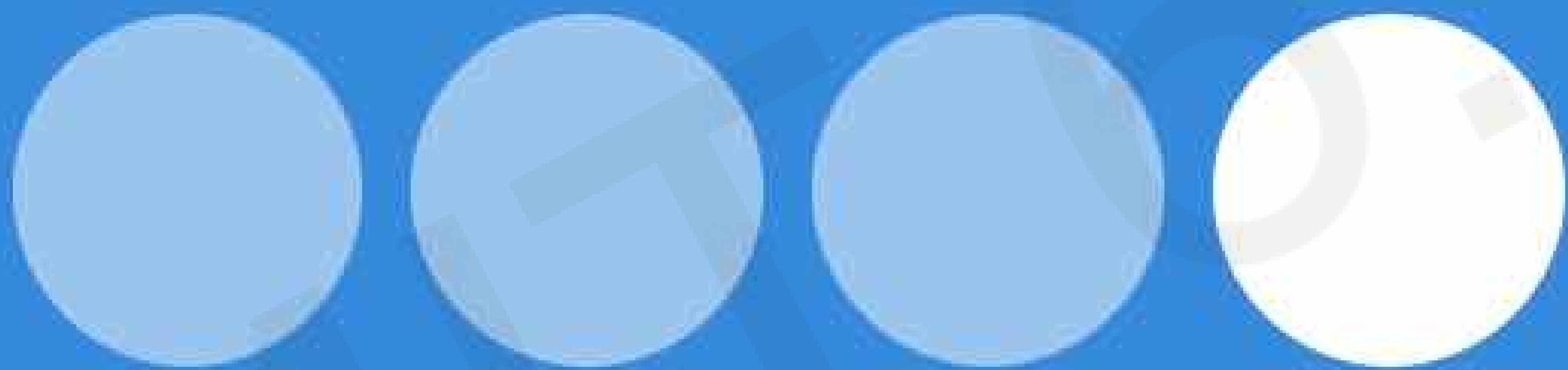

Given an image of a ball,
can you predict where it will go next?



Sequences in the Wild



Audio

Sequences in the Wild



08, 2019

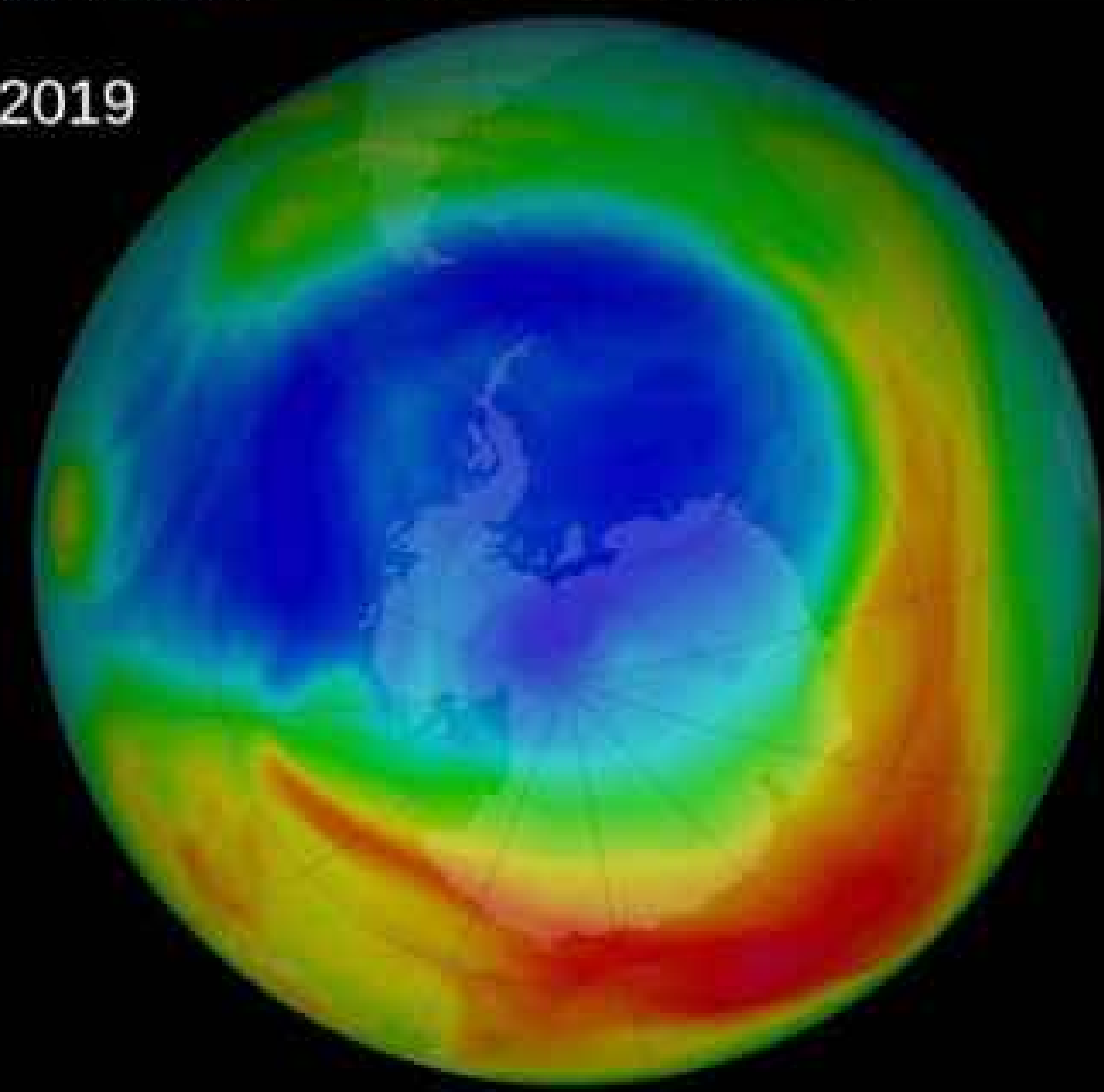

Sequence Modeling Applications

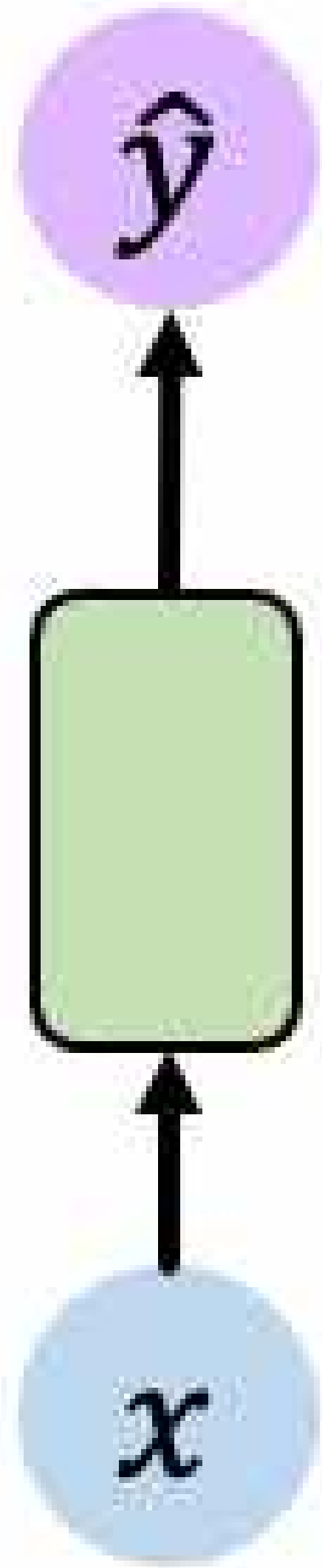

One to One
Binary Classification



“Will I pass this class?”
Student → Pass?

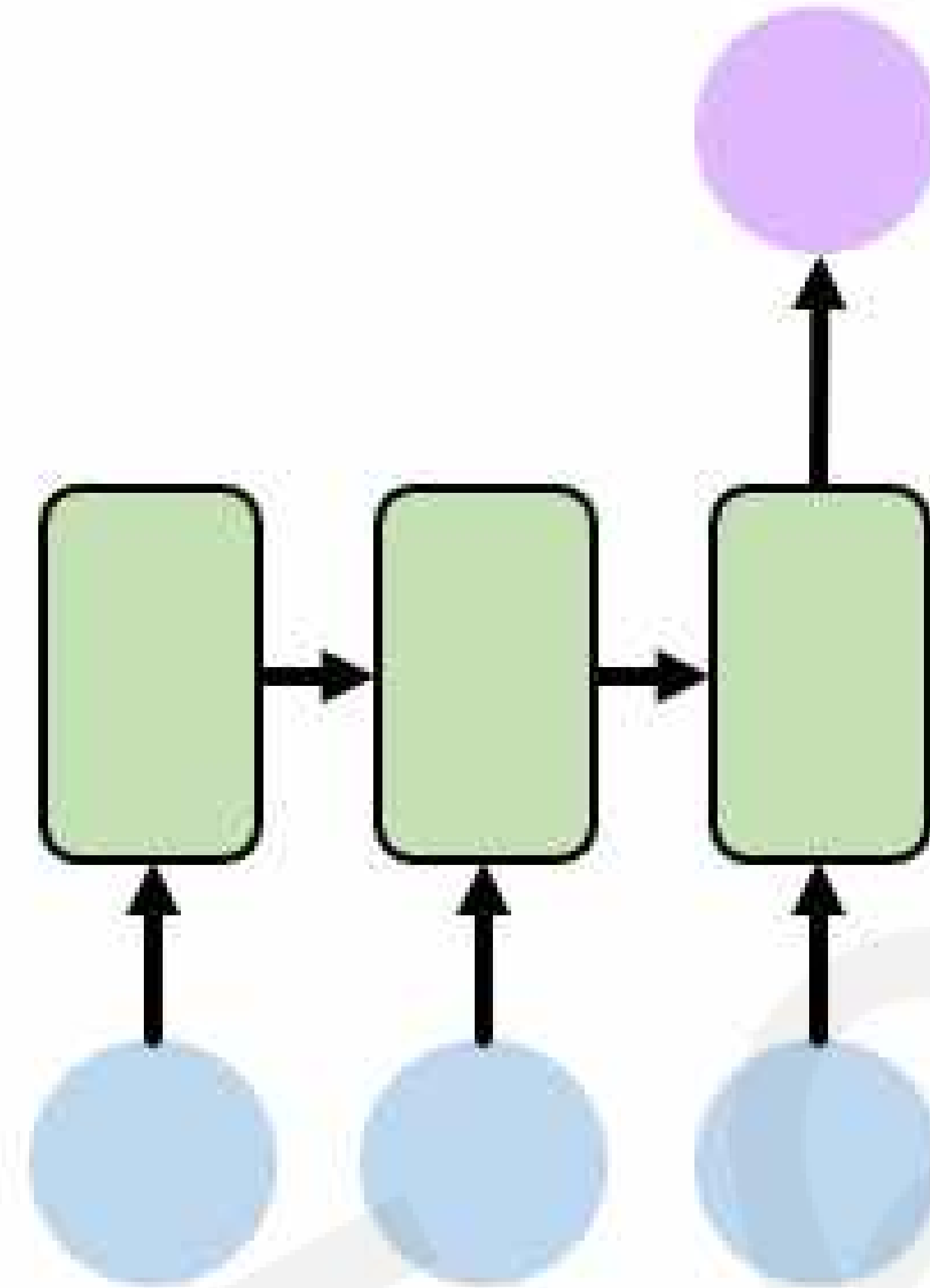

Many to One
Sentiment Classification

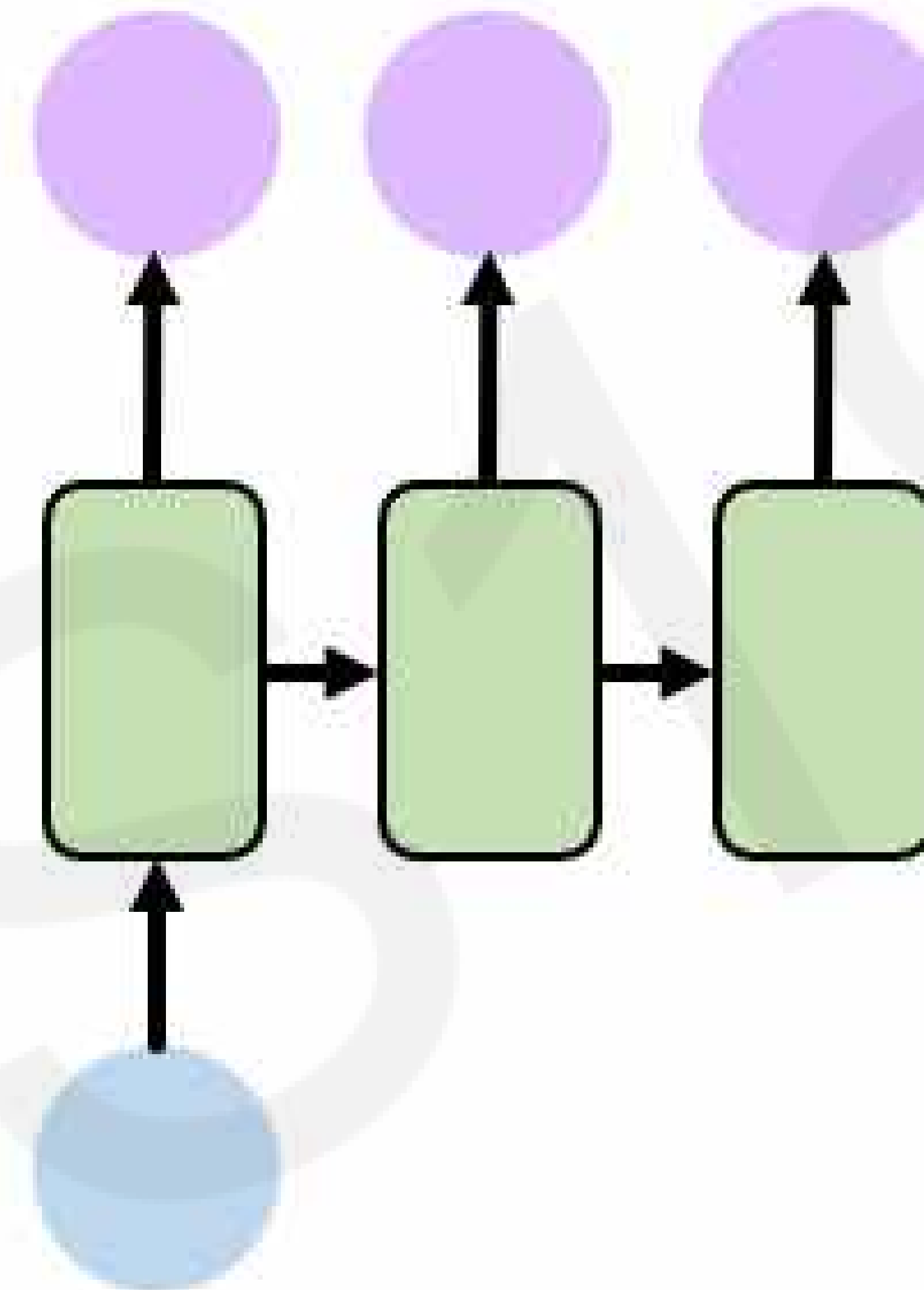

One to Many
Image Captioning



“A baseball player throws a ball.”

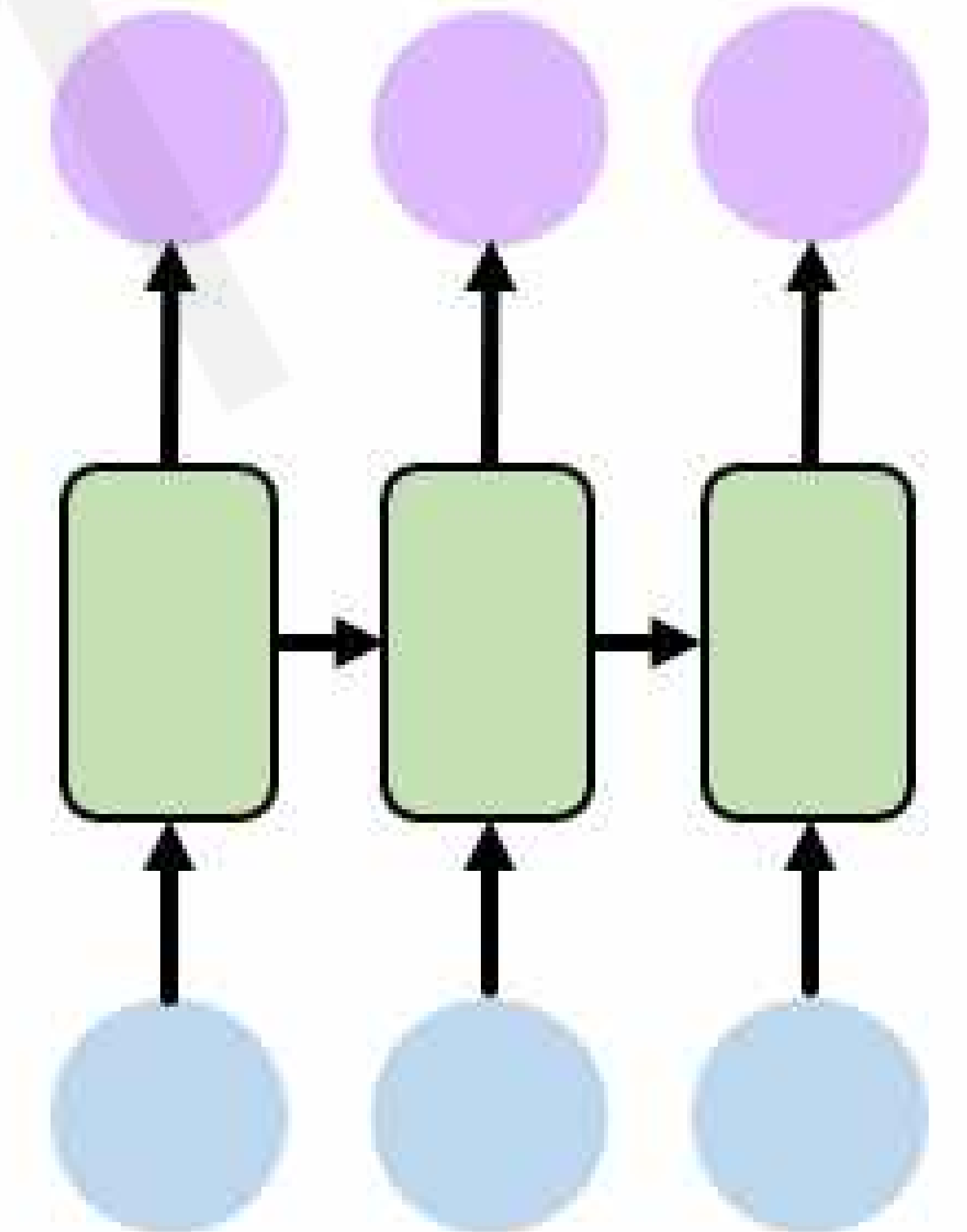

Many to Many
Machine Translation



Neurons with Recurrence

The Perceptron Revisited

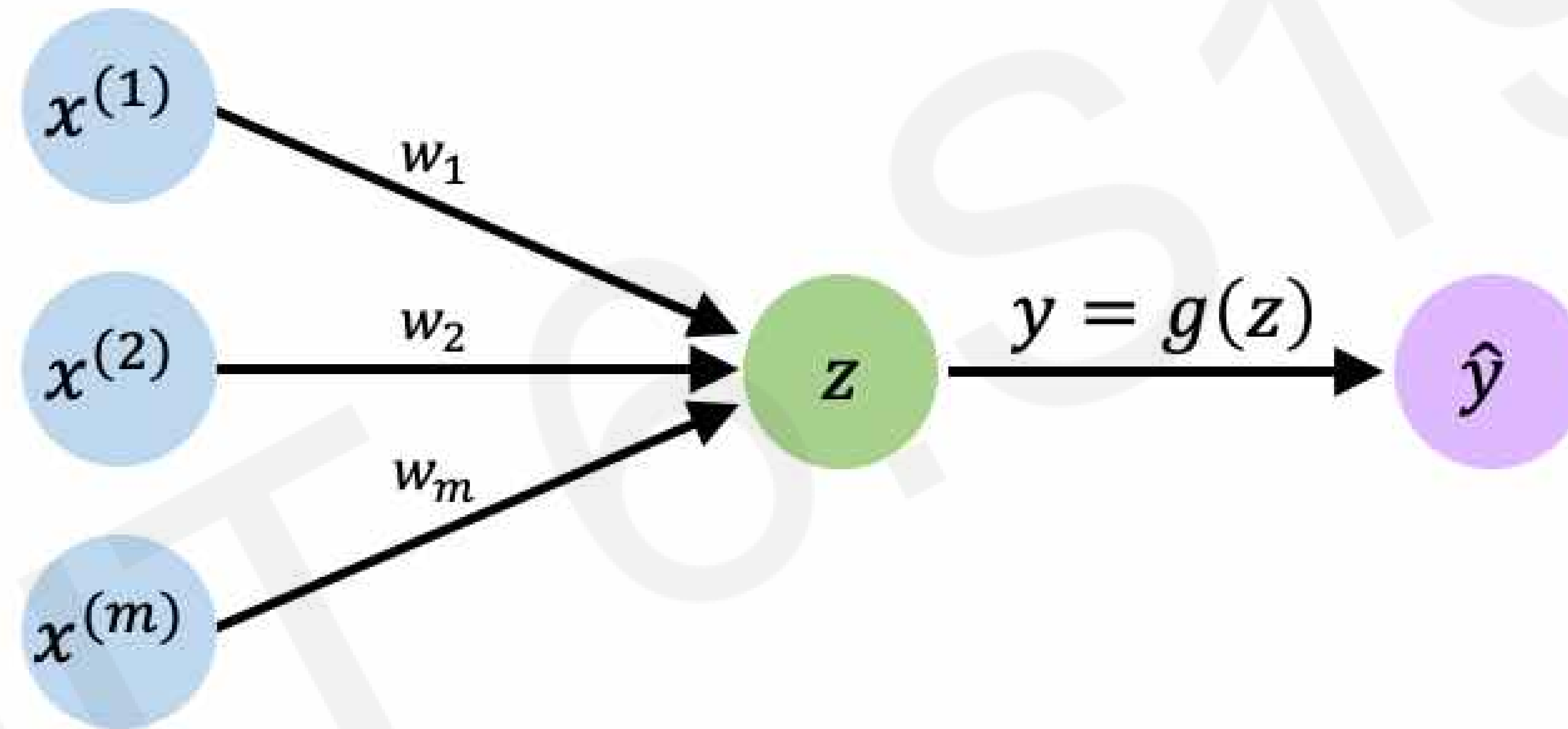

Feed-Forward Networks Revisited

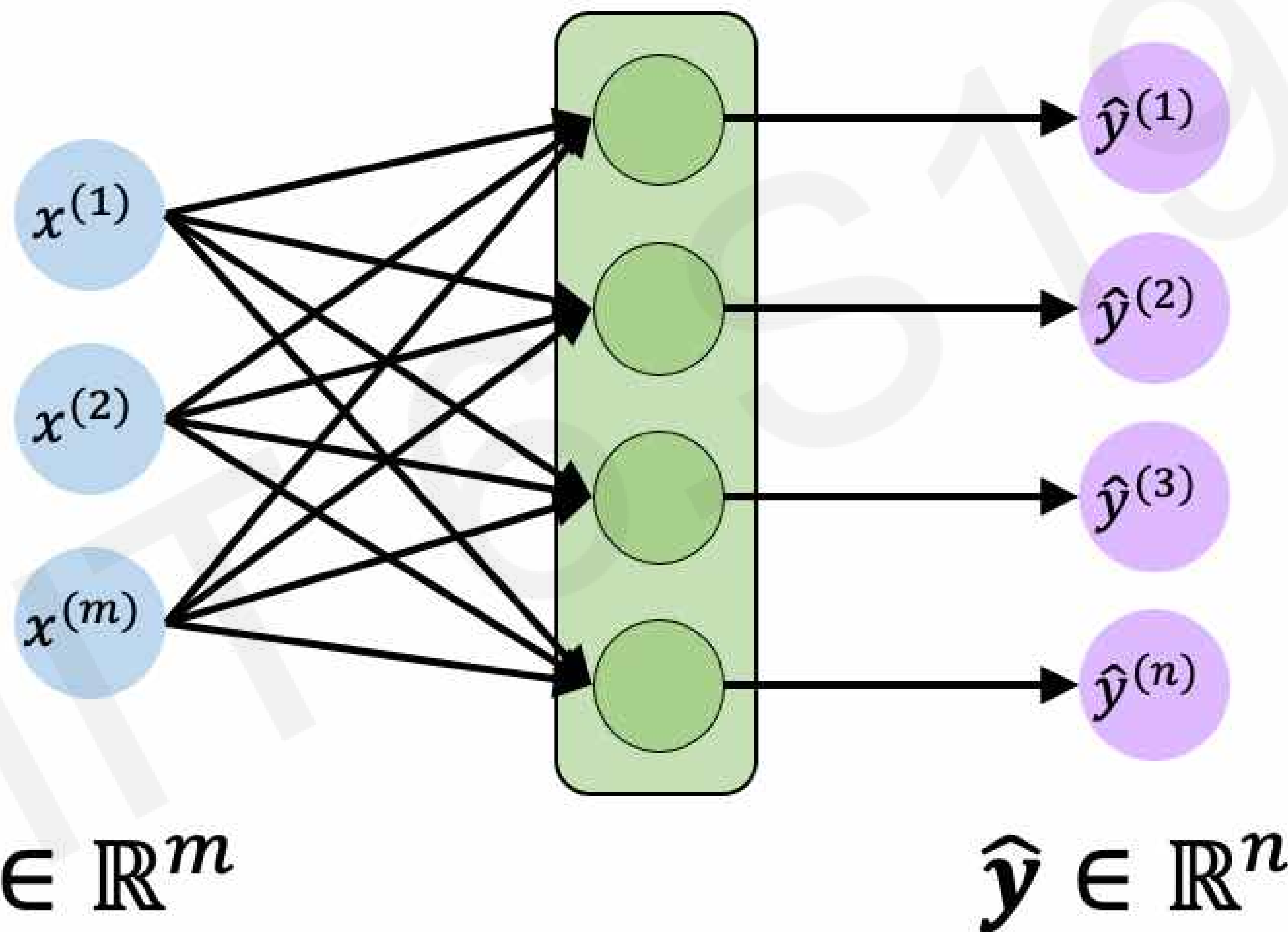

Feed-Forward Networks Revisited

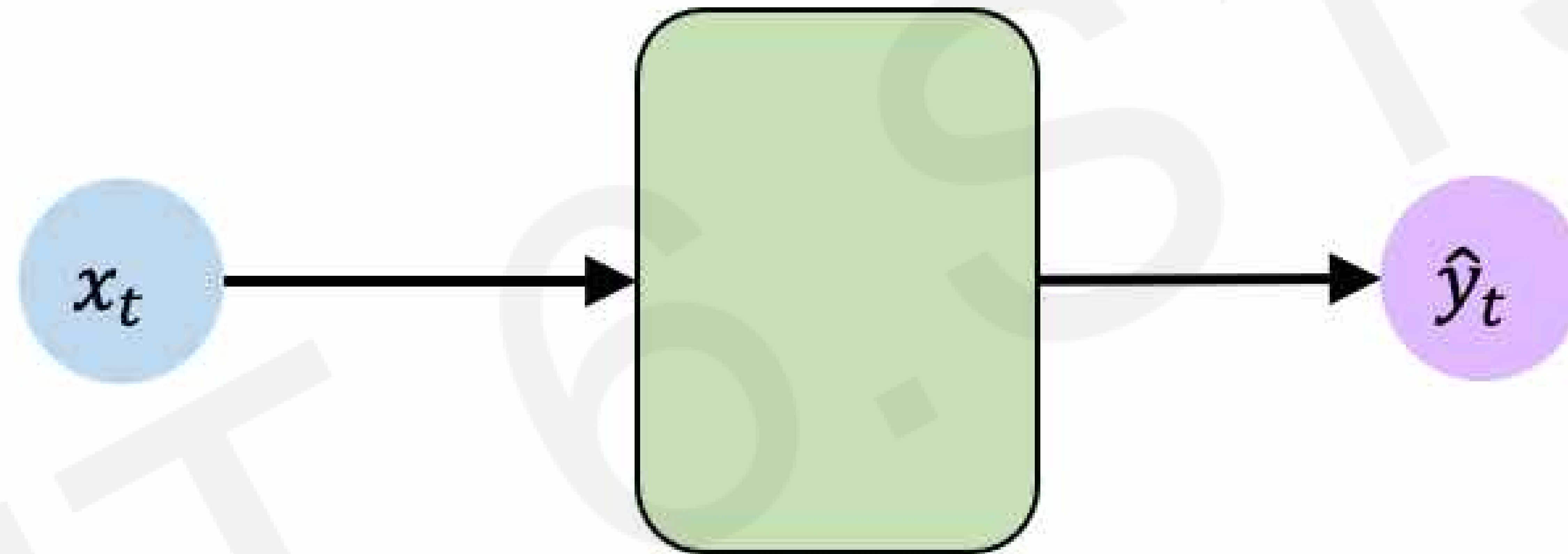

$$x_t \in \mathbb{R}^m$$

$$\hat{y}_t \in \mathbb{R}^n$$

Handling Individual Time Steps

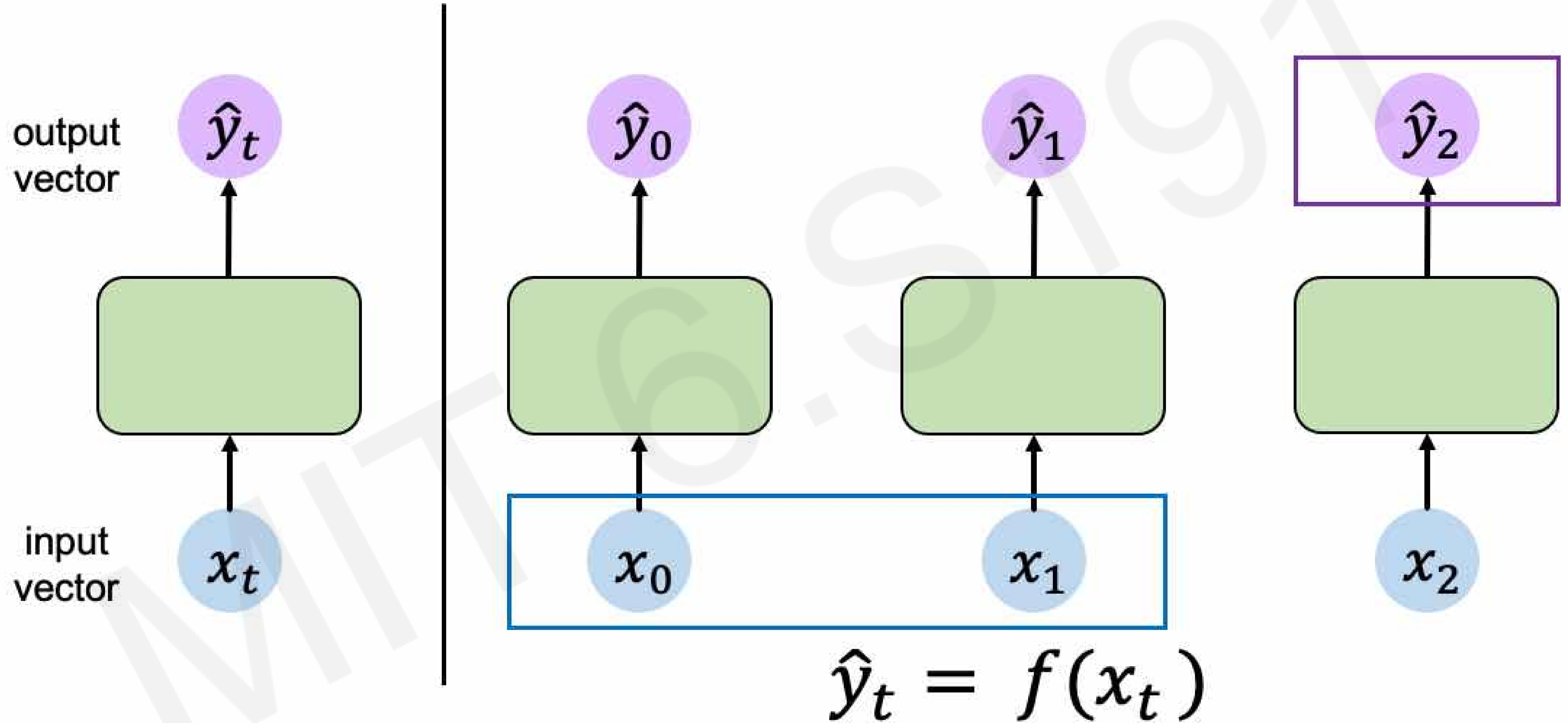

Neurons with Recurrence

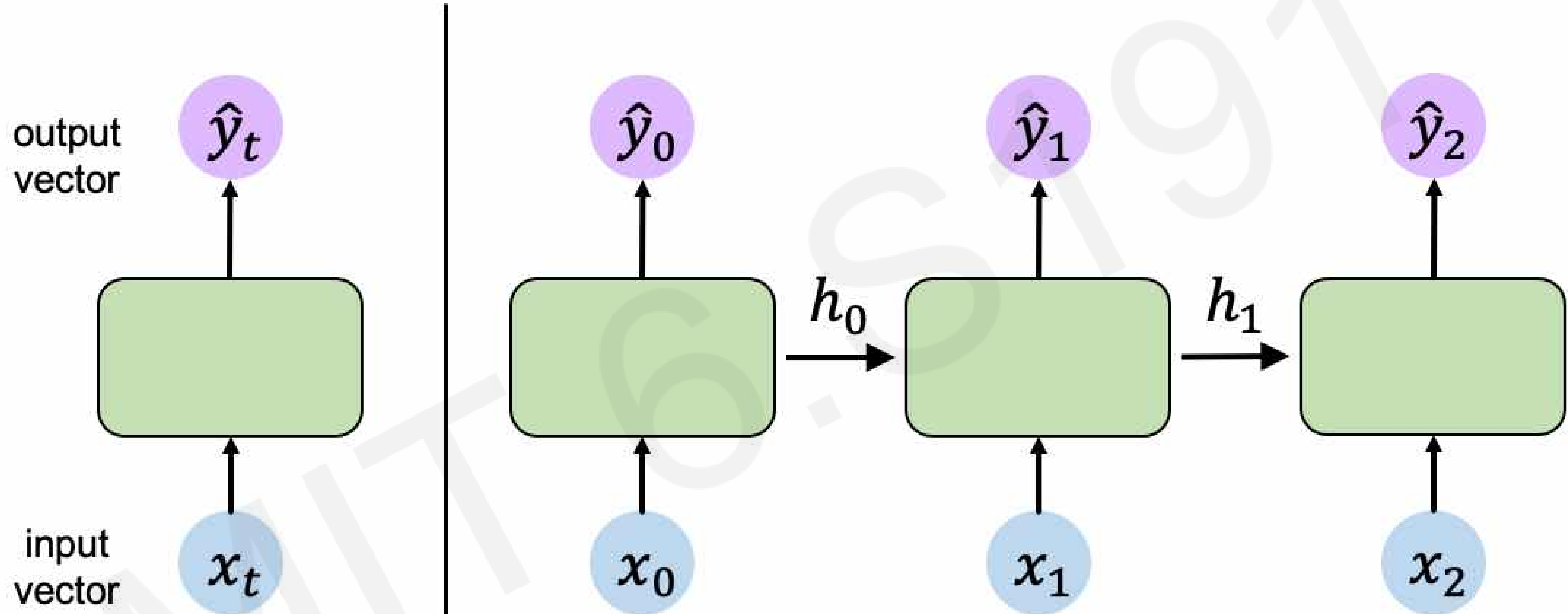

$$\hat{y}_t = f(x_t, h_{t-1})$$

output input past memory

Neurons with Recurrence

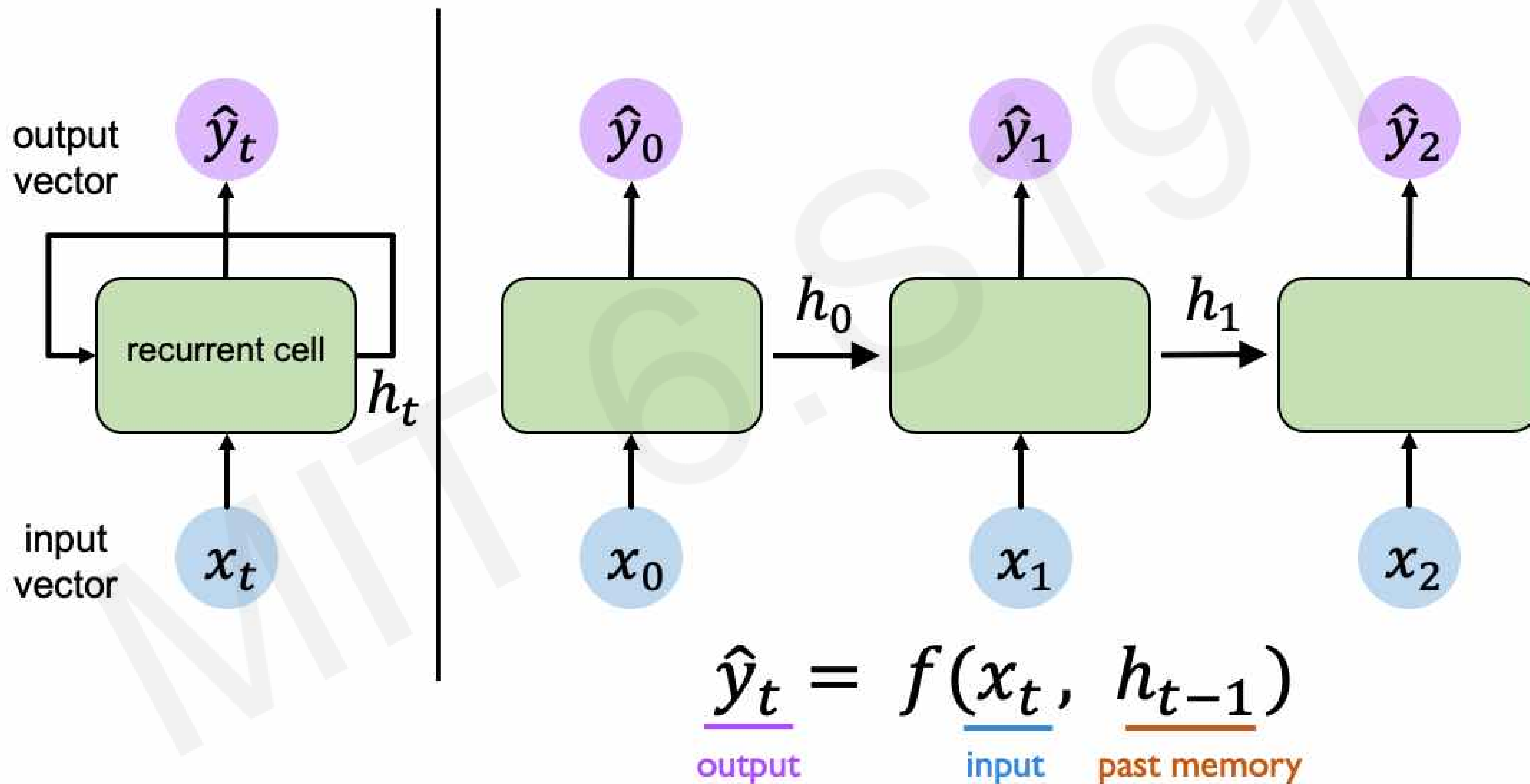

Recurrent Neural Networks (RNNs)

Recurrent Neural Networks (RNNs)

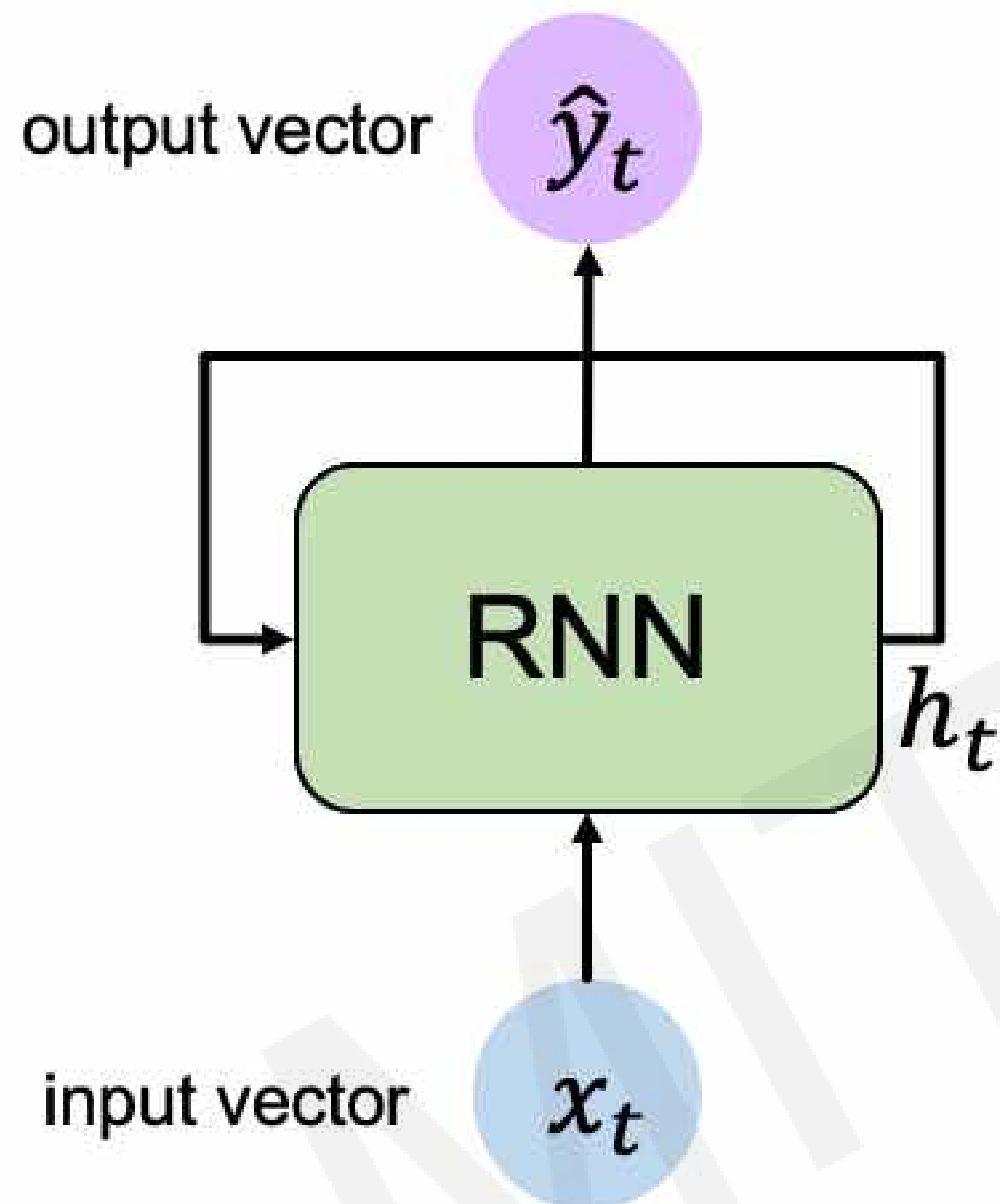

Apply a **recurrence relation** at every time step to process a sequence:

$$h_t = f_W(x_t, h_{t-1})$$

cell state function with weights W input old state

Note: the same function and set of parameters are used at every time step

RNNs have a **state**, h_t , that is updated **at each time step** as a sequence is processed

RNN Intuition

```
my_rnn = RNN()
hidden_state = [0, 0, 0, 0]

sentence = ["I", "love", "recurrent", "neural"]
```

```
for word in sentence:
    prediction, hidden_state = my_rnn(word, hidden_state)
```

```
next_word_prediction = prediction
```

```
# >>> "networks!"
```

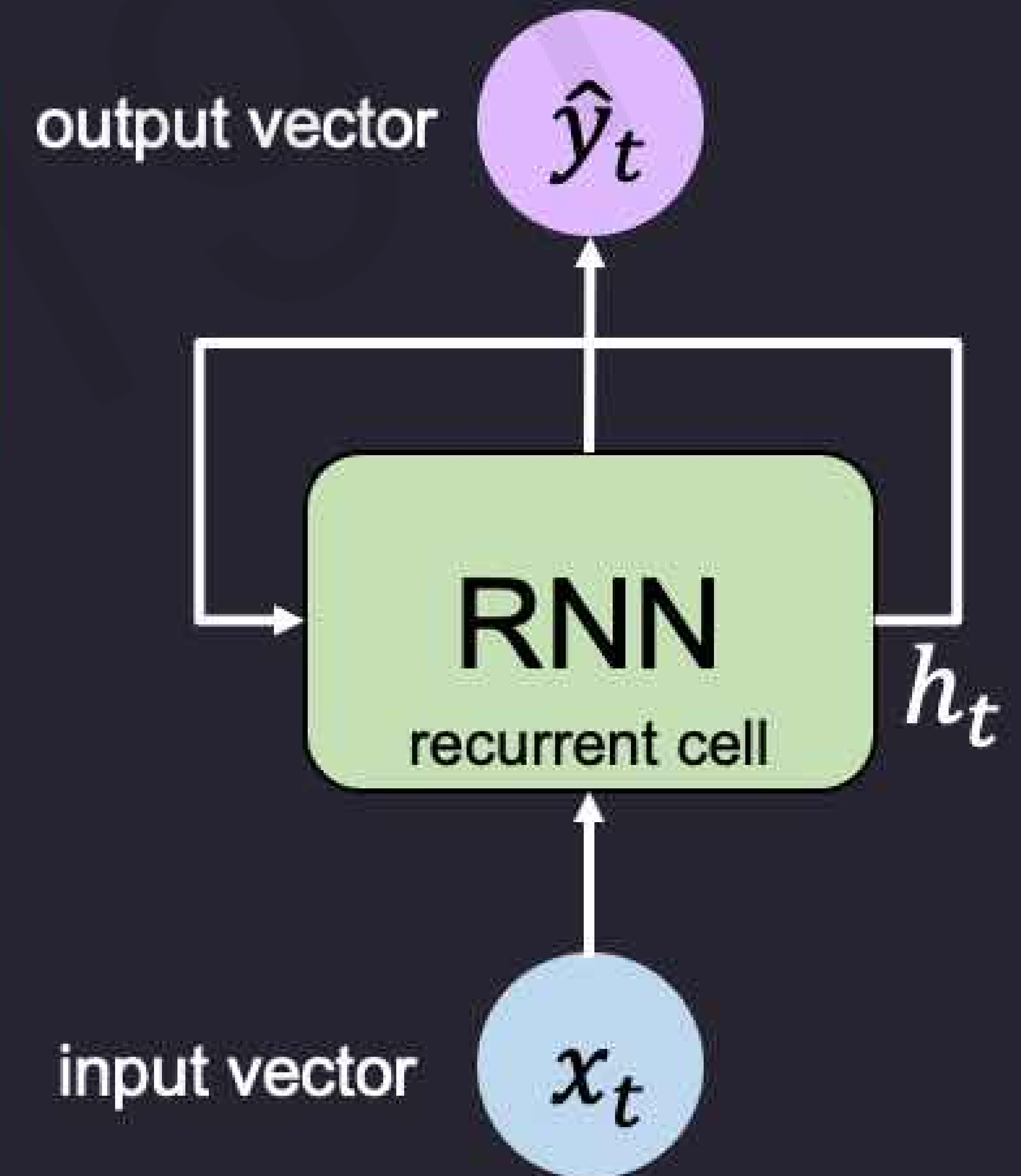

RNN Intuition

```
my_rnn = RNN()
hidden_state = [0, 0, 0, 0]

sentence = ["I", "love", "recurrent", "neural"]
```

```
for word in sentence:
    prediction, hidden_state = my_rnn(word, hidden_state)
```

```
next_word_prediction = prediction
```

```
# >>> "networks!"
```

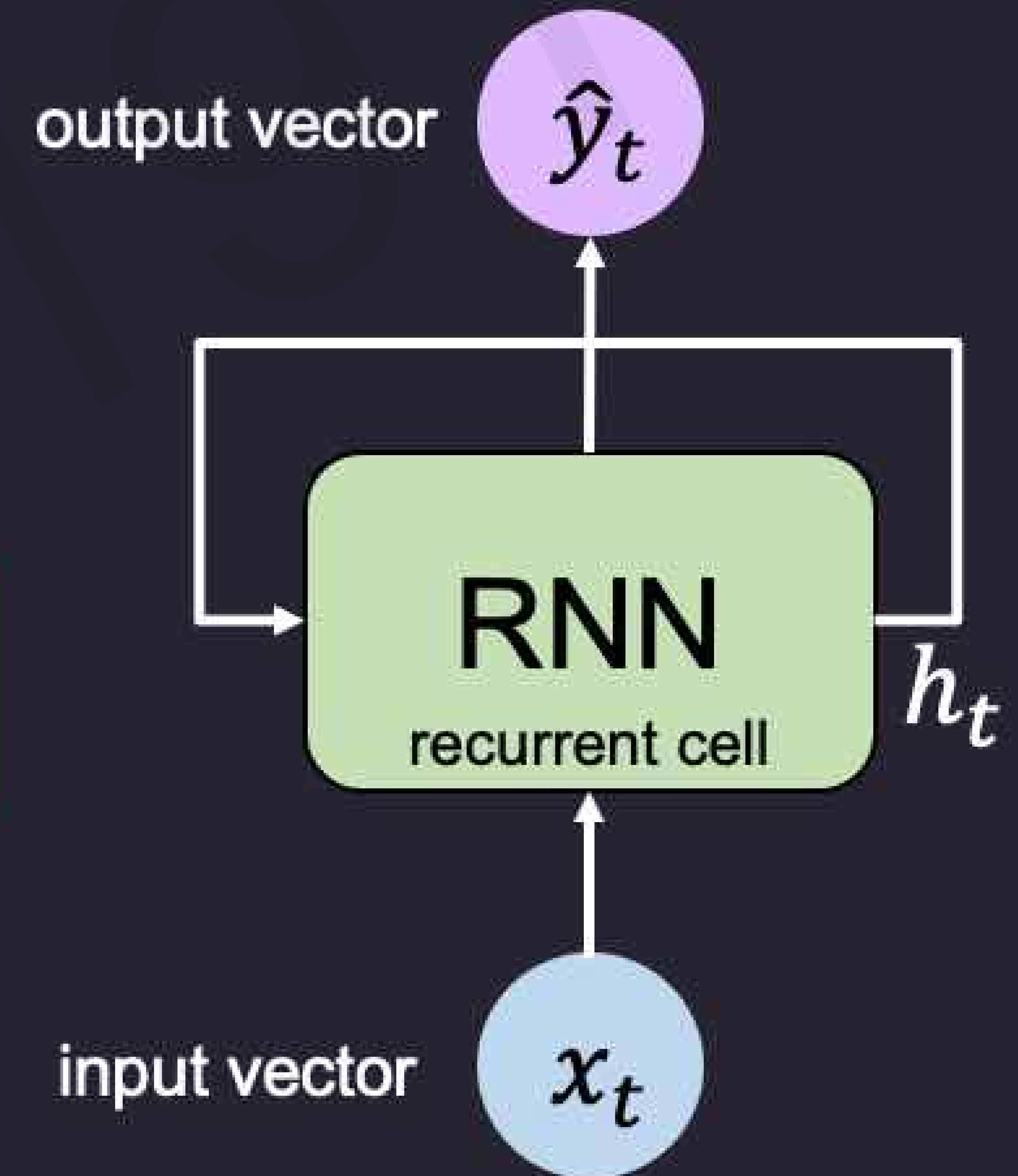

RNN Intuition

```
my_rnn = RNN()
hidden_state = [0, 0, 0, 0]

sentence = ["I", "love", "recurrent", "neural"]

for word in sentence:
    prediction, hidden_state = my_rnn(word, hidden_state)

next_word_prediction = prediction
# >>> "networks!"
```

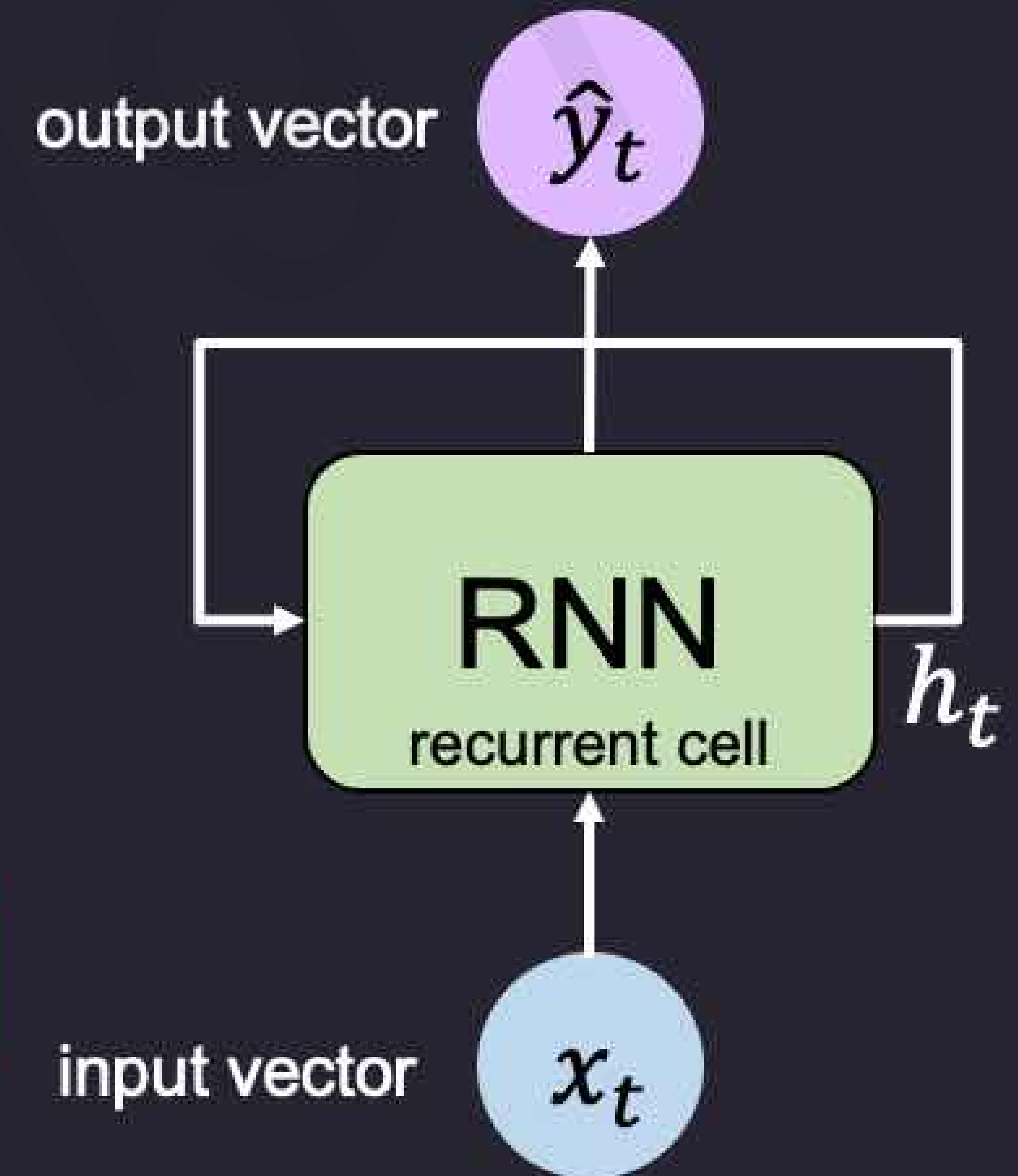

RNN State Update and Output

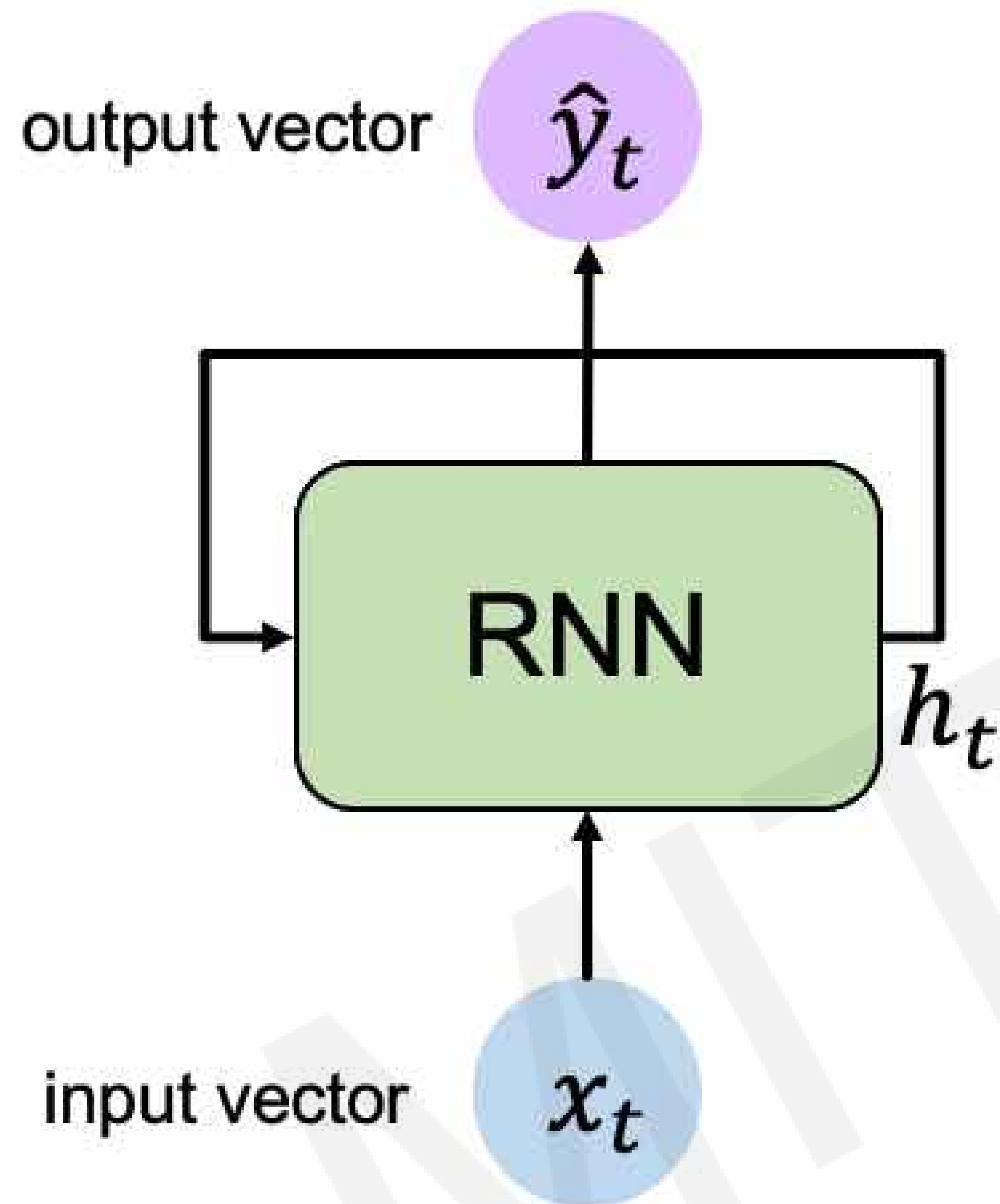

RNN State Update and Output

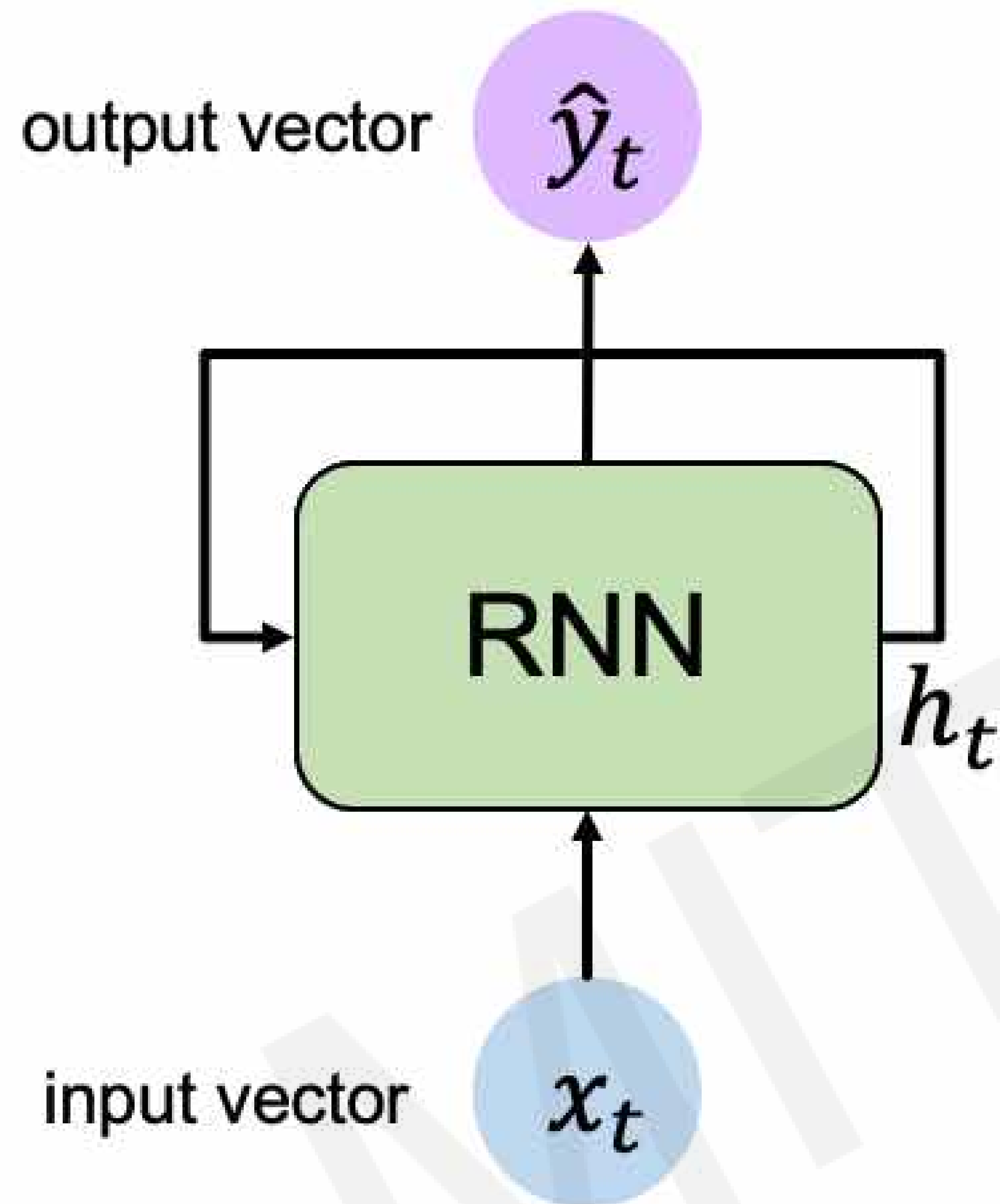

Input Vector

x_t

RNN State Update and Output

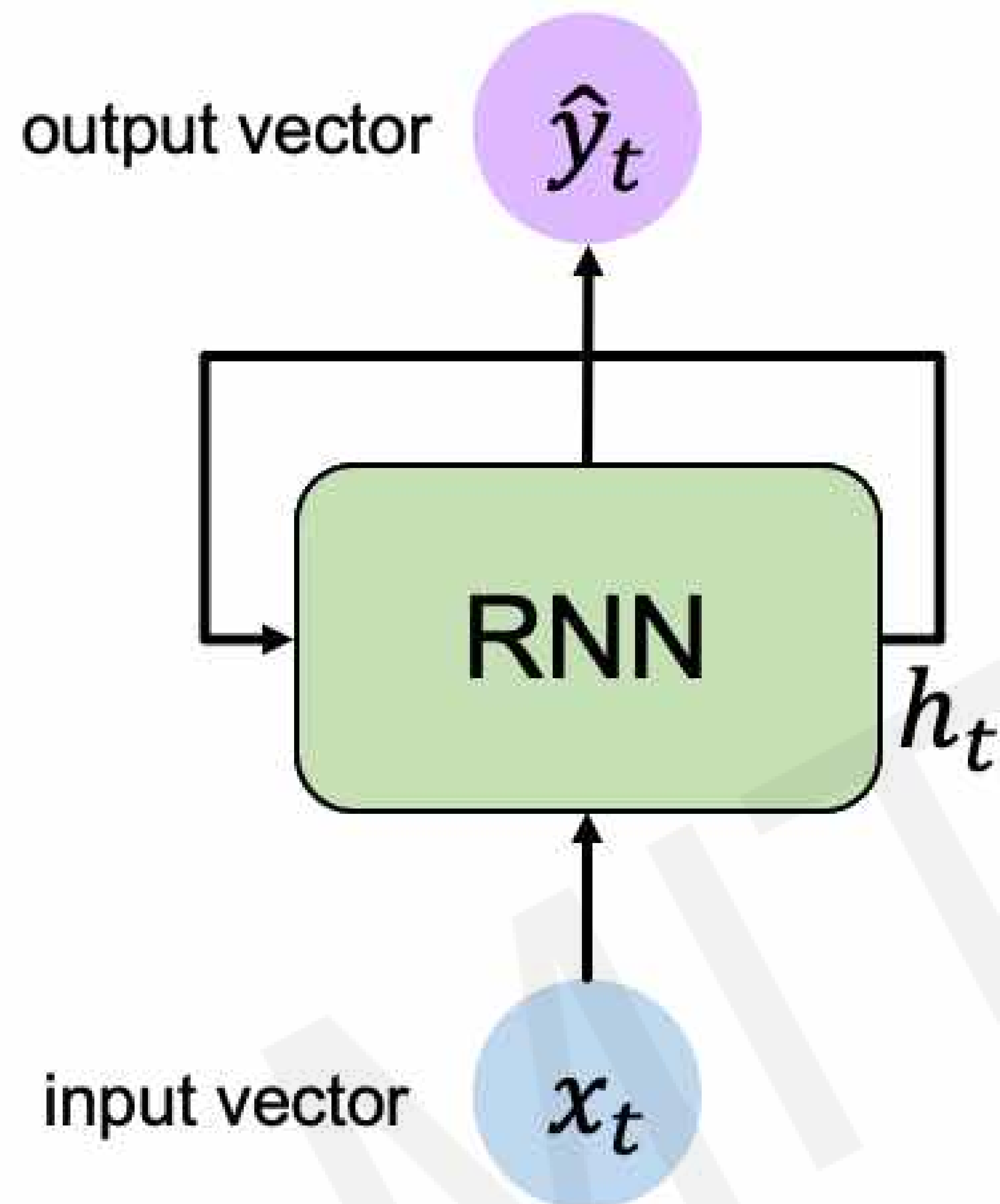

Update Hidden State

$$h_t = \tanh(W_{hh}^T h_{t-1} + W_{xh}^T x_t)$$

Input Vector

x_t

RNN State Update and Output

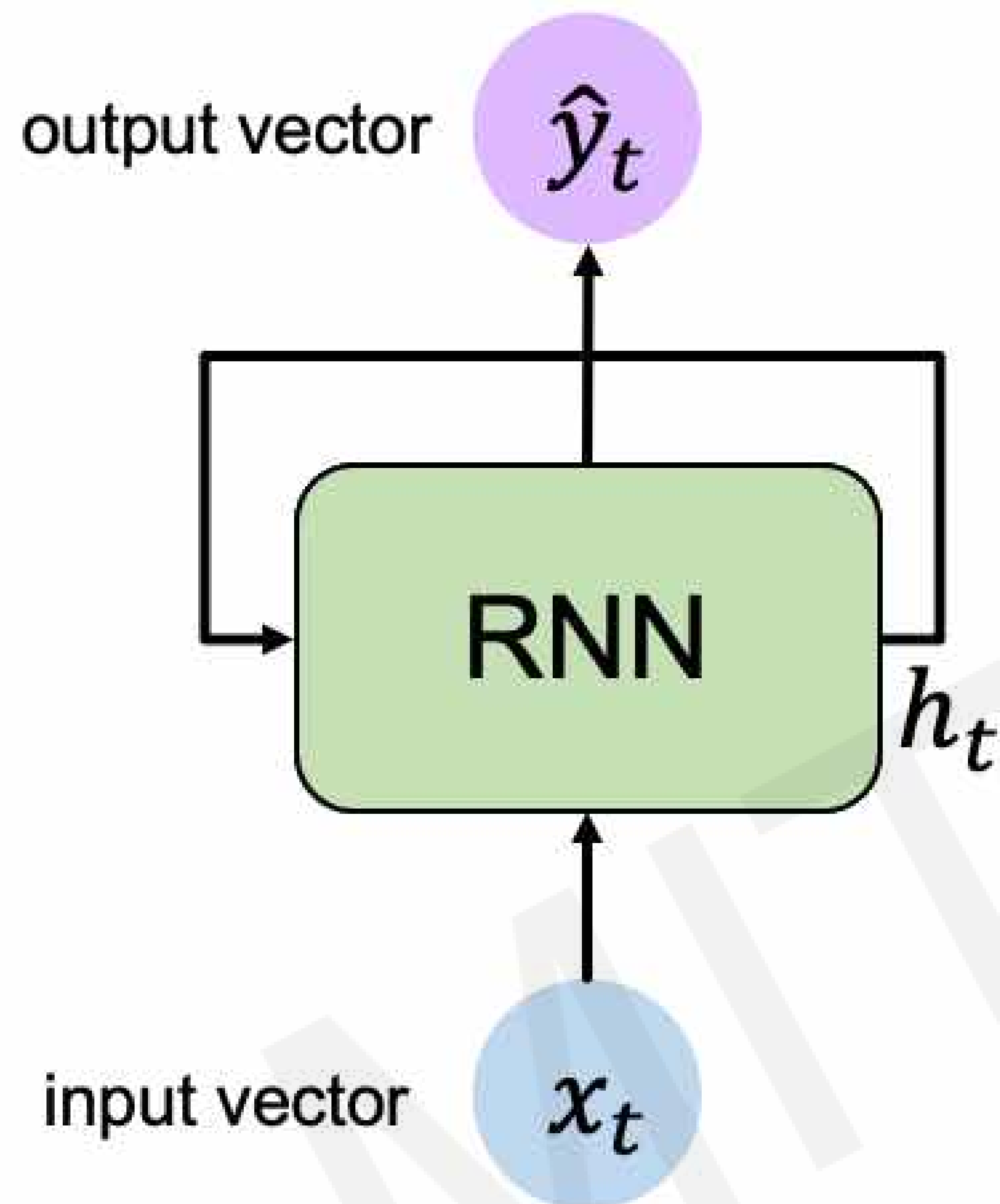

Output Vector

$$\hat{y}_t = \mathbf{W}_{hy}^T h_t$$

Update Hidden State

$$h_t = \tanh(\mathbf{W}_{hh}^T h_{t-1} + \mathbf{W}_{xh}^T x_t)$$

Input Vector

x_t

RNNs: Computational Graph Across Time

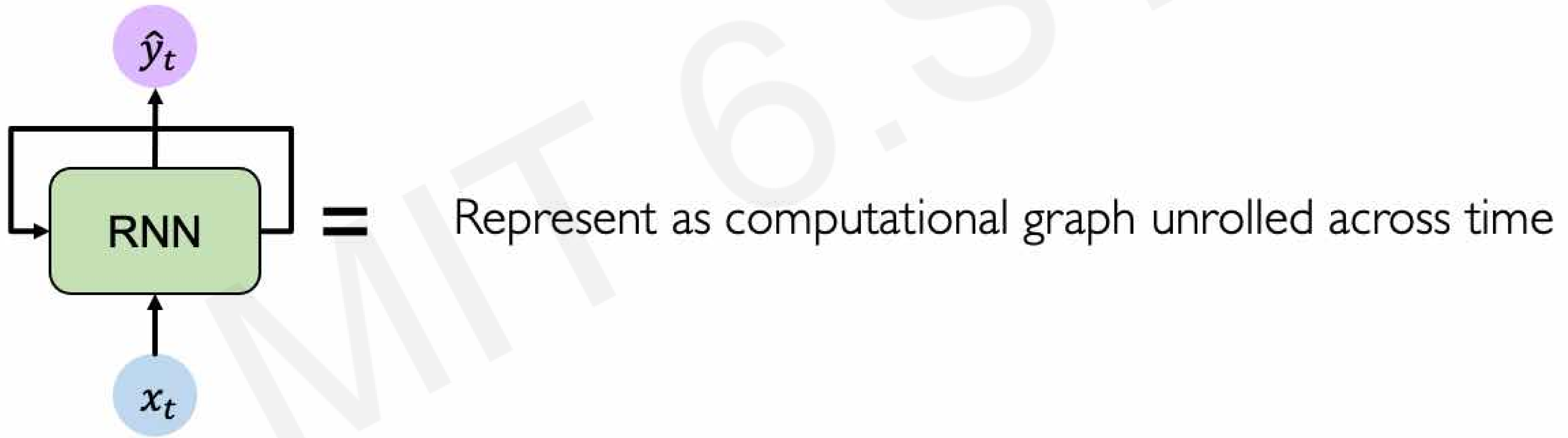

RNNs: Computational Graph Across Time

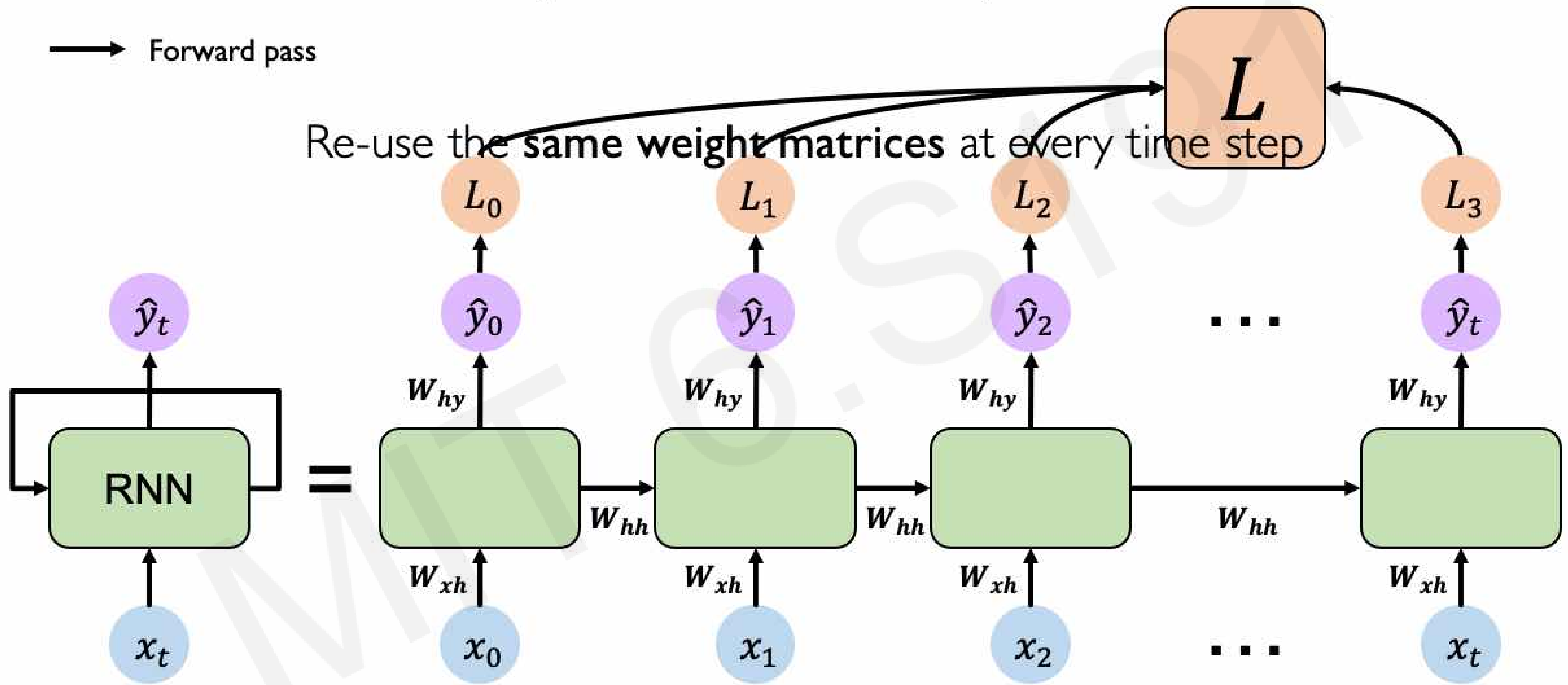

RNNs from Scratch



```
class MyRNNCell(tf.keras.layers.Layer):  
    def __init__(self, rnn_units, input_dim, output_dim):  
        super(MyRNNCell, self).__init__()  
  
        # Initialize weight matrices  
        self.W_xh = self.add_weight([rnn_units, input_dim])  
        self.W_hh = self.add_weight([rnn_units, rnn_units])  
        self.W_hy = self.add_weight([output_dim, rnn_units])  
  
        # Initialize hidden state to zeros  
        self.h = tf.zeros([rnn_units, 1])  
  
    def call(self, x):  
        # Update the hidden state  
        self.h = tf.math.tanh( self.W_hh * self.h + self.W_xh * x )  
  
        # Compute the output  
        output = self.W_hy * self.h  
  
        # Return the current output and hidden state  
        return output, self.h
```

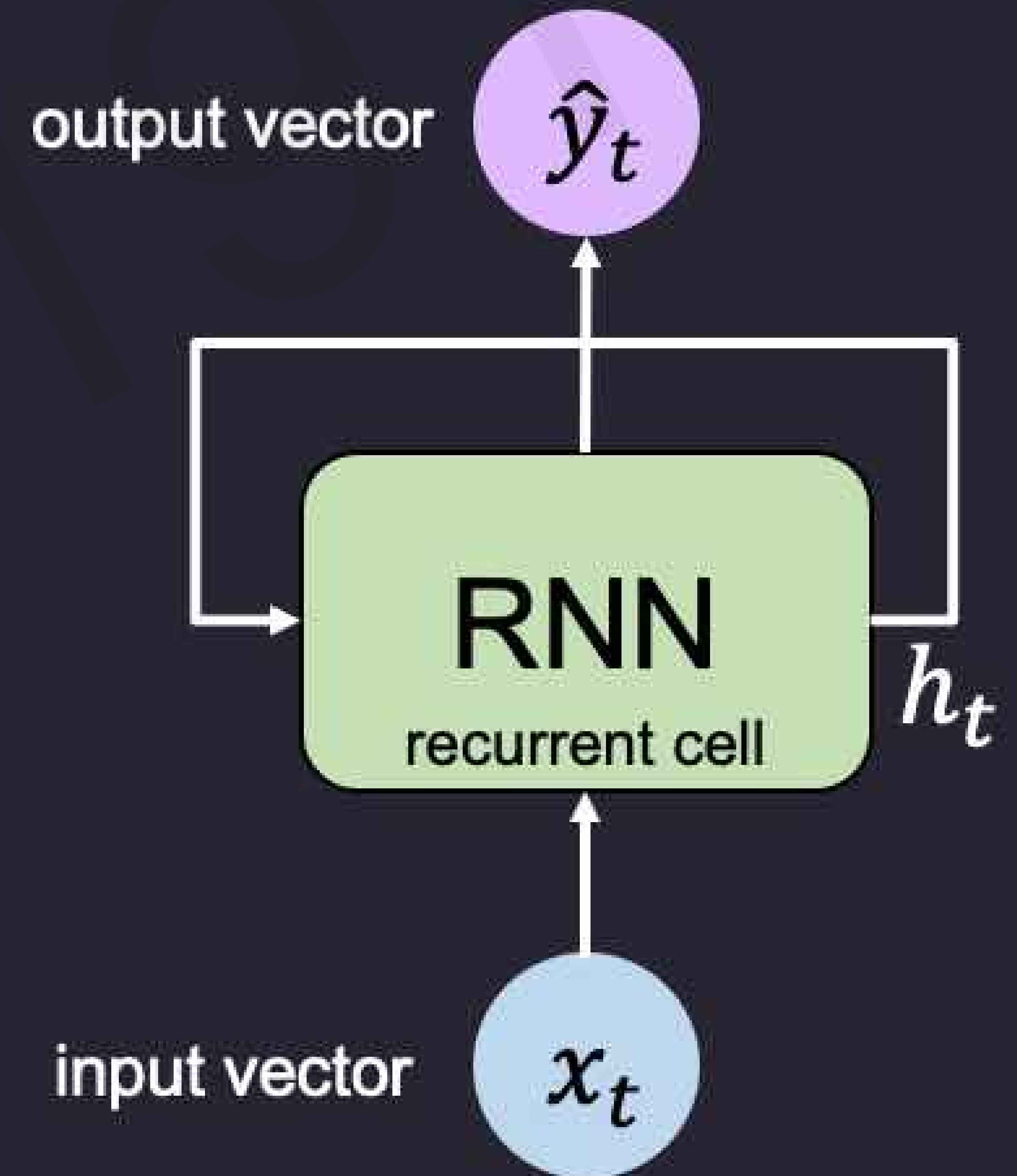

RNN Implementation in TensorFlow



```
tf.keras.layers.SimpleRNN(rnn_units)
```

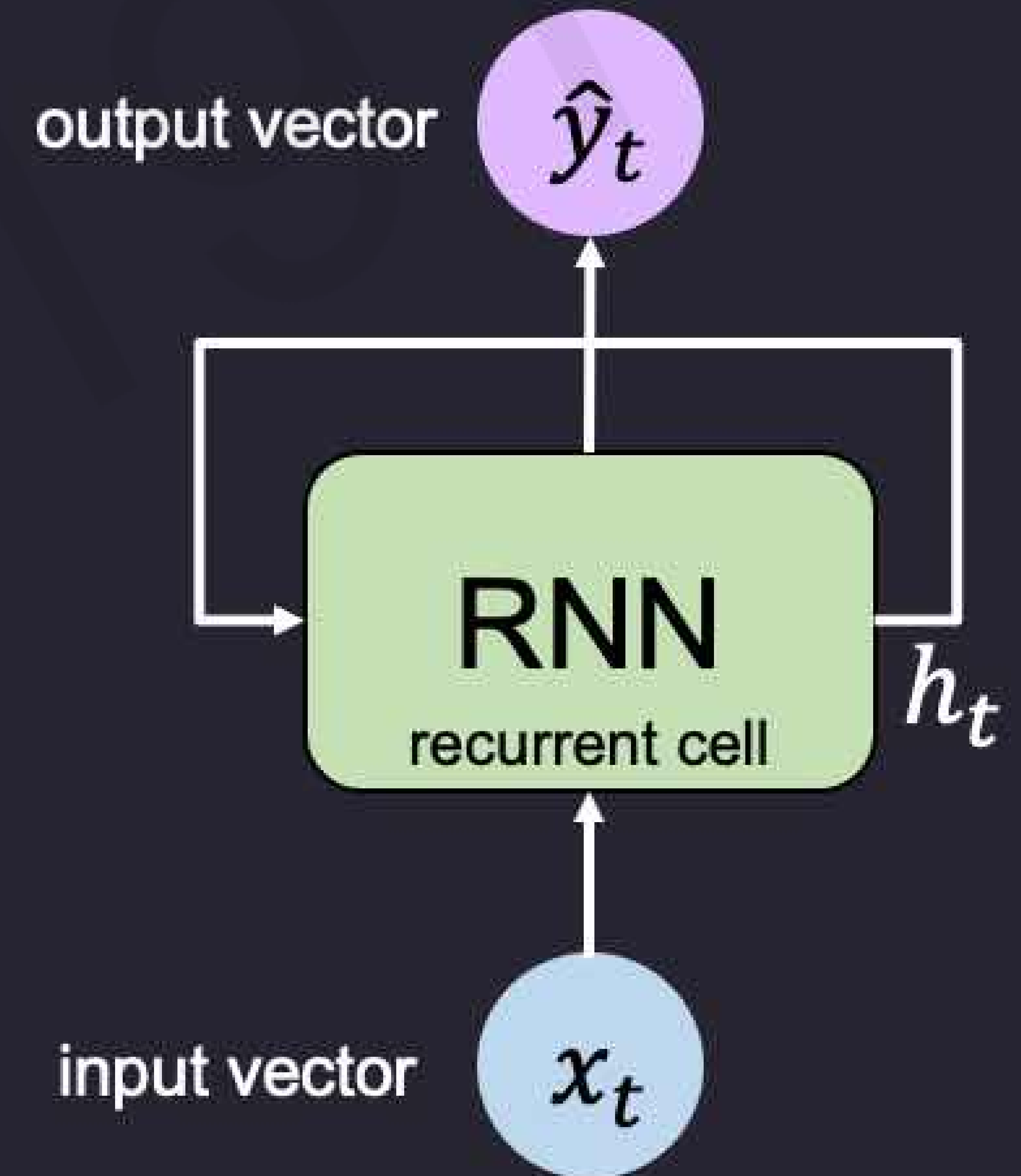

RNNs for Sequence Modeling

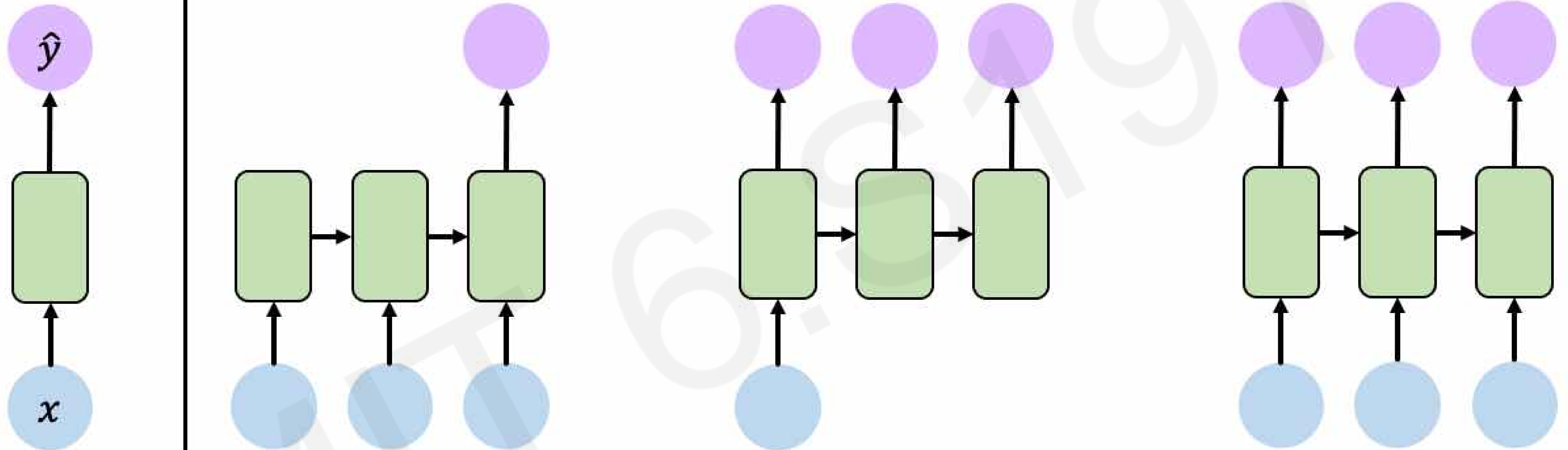

One to One
"Vanilla" NN
Binary classification

Many to One
Sentiment Classification

One to Many
Text Generation
Image Captioning

Many to Many
Translation & Forecasting
Music Generation

... and many other architectures and applications



Sequence Modeling: Design Criteria

To model sequences, we need to:

1. Handle **variable-length** sequences
2. Track **long-term** dependencies
3. Maintain information about **order**
4. **Share parameters** across the sequence

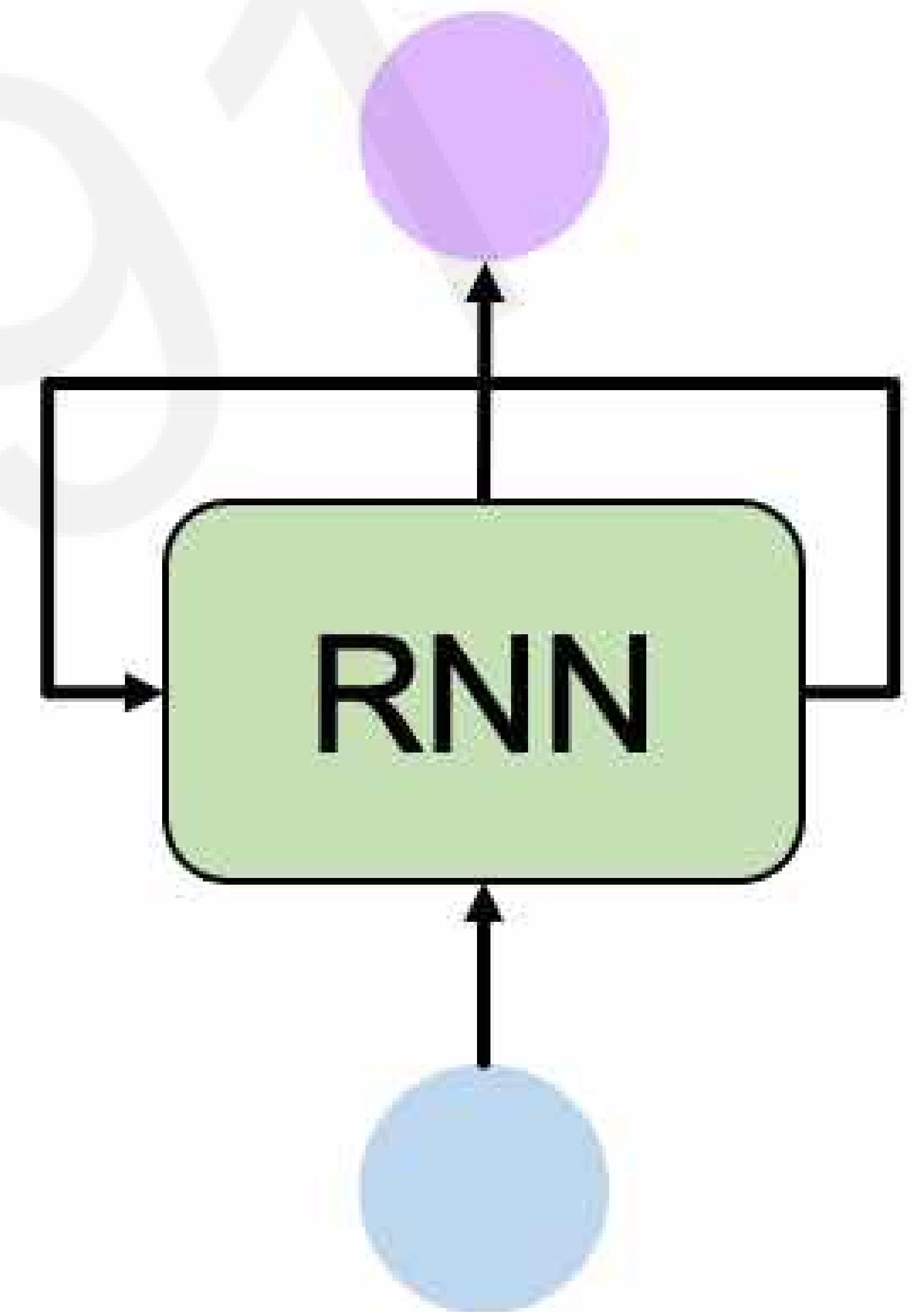

Recurrent Neural Networks (RNNs) meet these sequence modeling design criteria

A Sequence Modeling Problem: Predict the Next Word

A Sequence Modeling Problem: Predict the Next Word

“This morning I took my cat for a walk.”

MIT 6.S191

A Sequence Modeling Problem: Predict the Next Word

“This morning I took my cat for a walk.”

given these words

MIT

6.S191

9

1

A Sequence Modeling Problem: Predict the Next Word

“This morning I took my cat for a walk.”

given these words

predict the
next word

MIT

6.S191

A Sequence Modeling Problem: Predict the Next Word

“This morning I took my cat for a walk.”

given these words

predict the
next word

Representing Language to a Neural Network

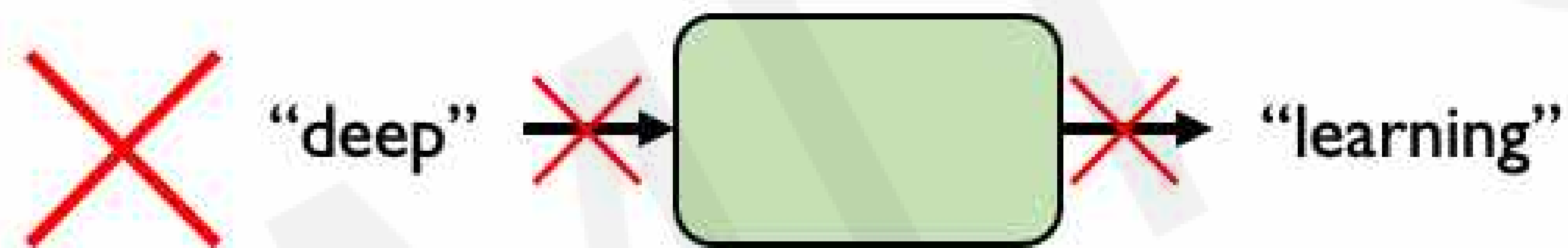

Neural networks cannot interpret words

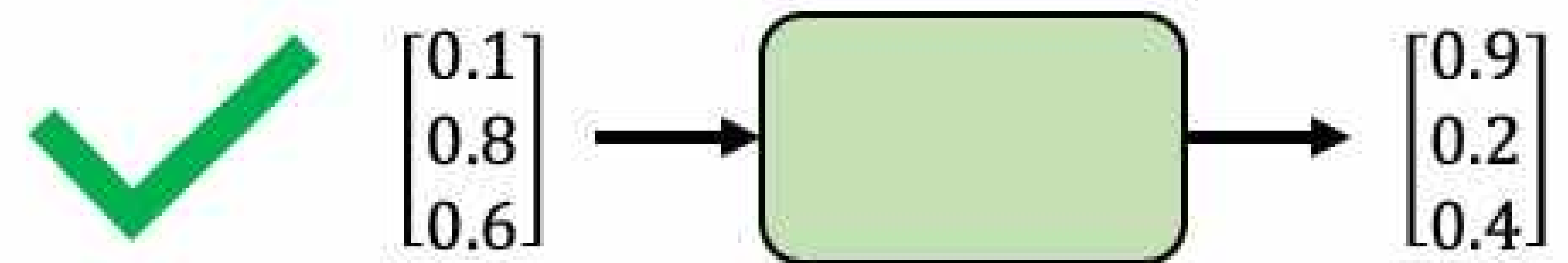

Neural networks require numerical inputs

Encoding Language for a Neural Network

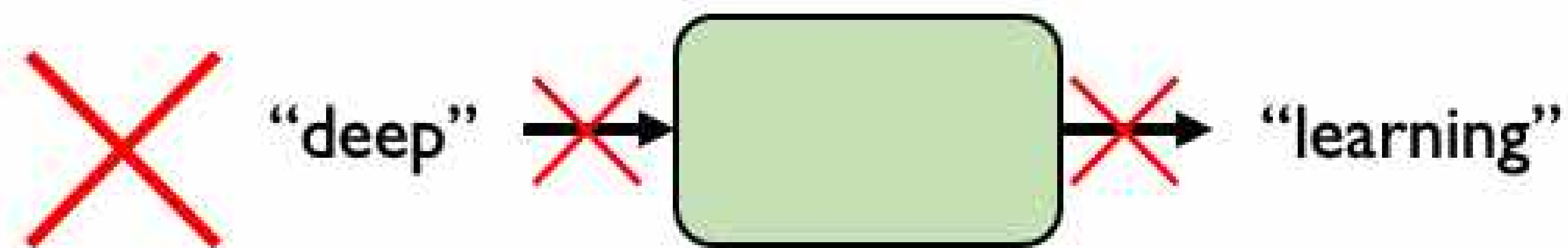

Neural networks cannot interpret words

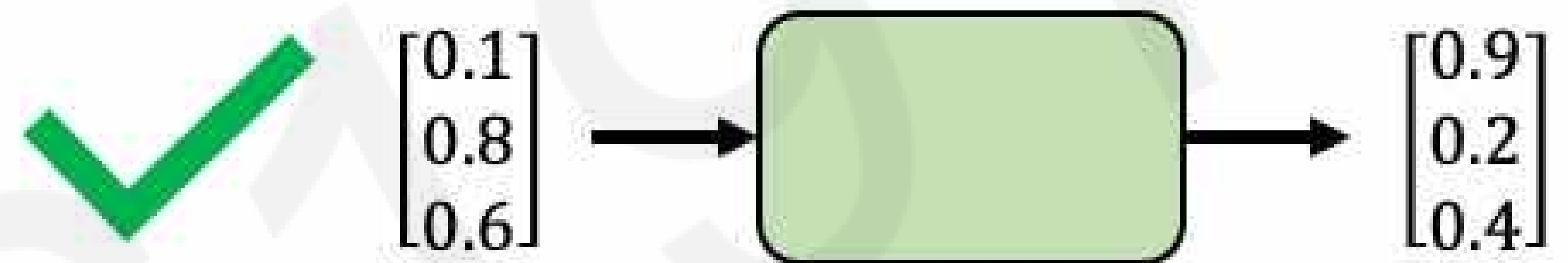

Neural networks require numerical inputs

Embedding: transform indexes into a vector of fixed size.

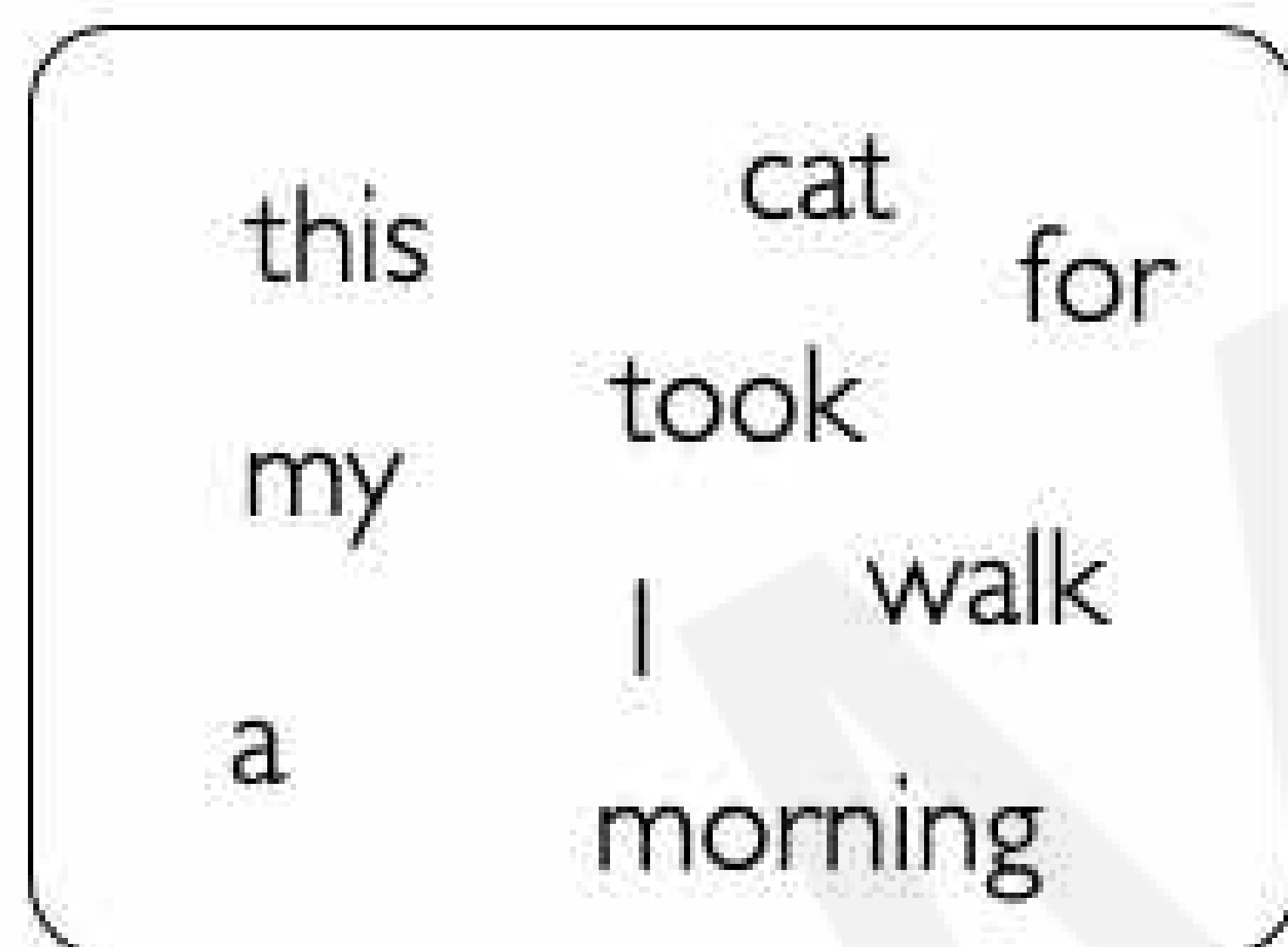

1. Vocabulary:
Corpus of words

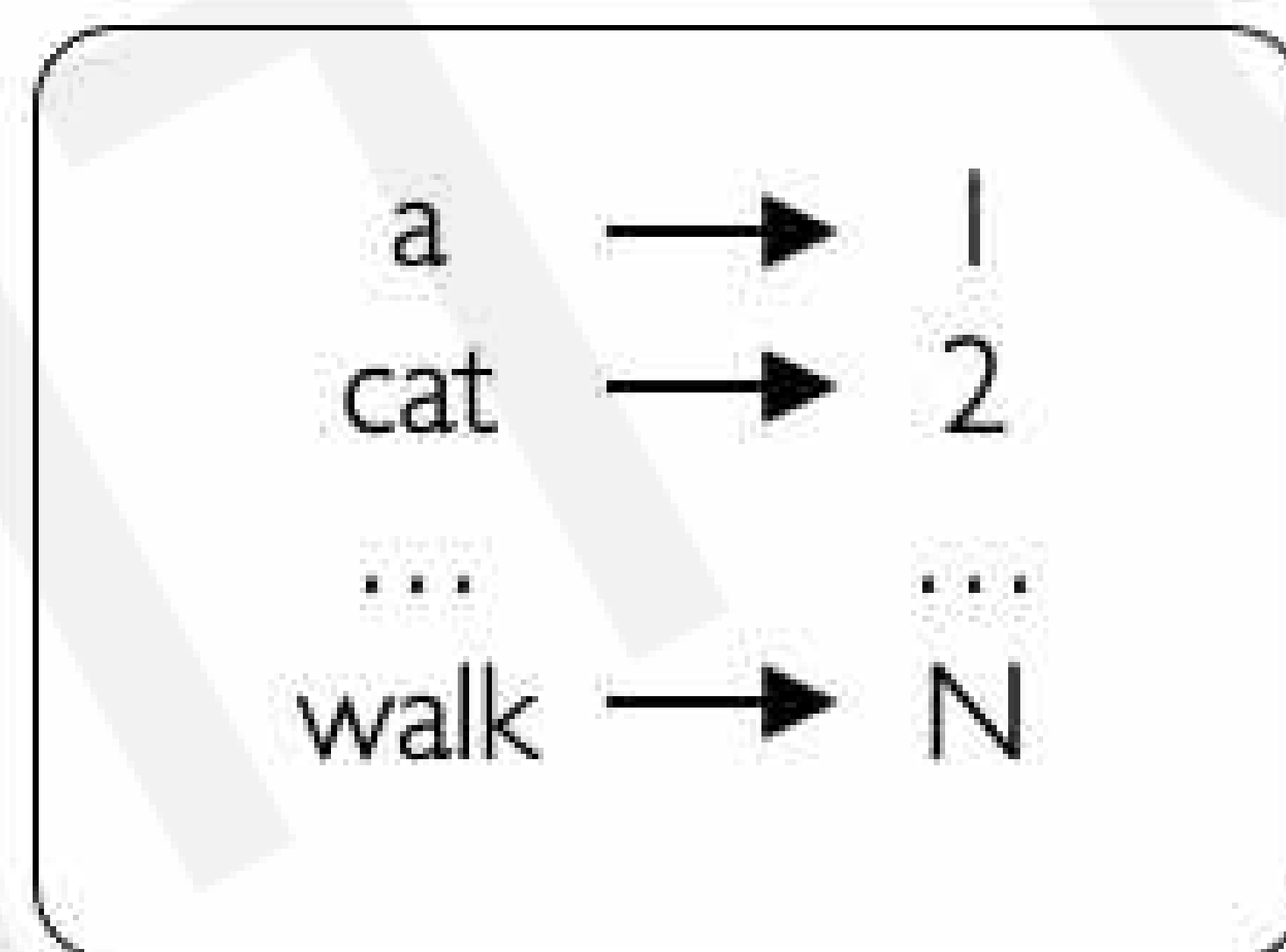

2. Indexing:
Word to index

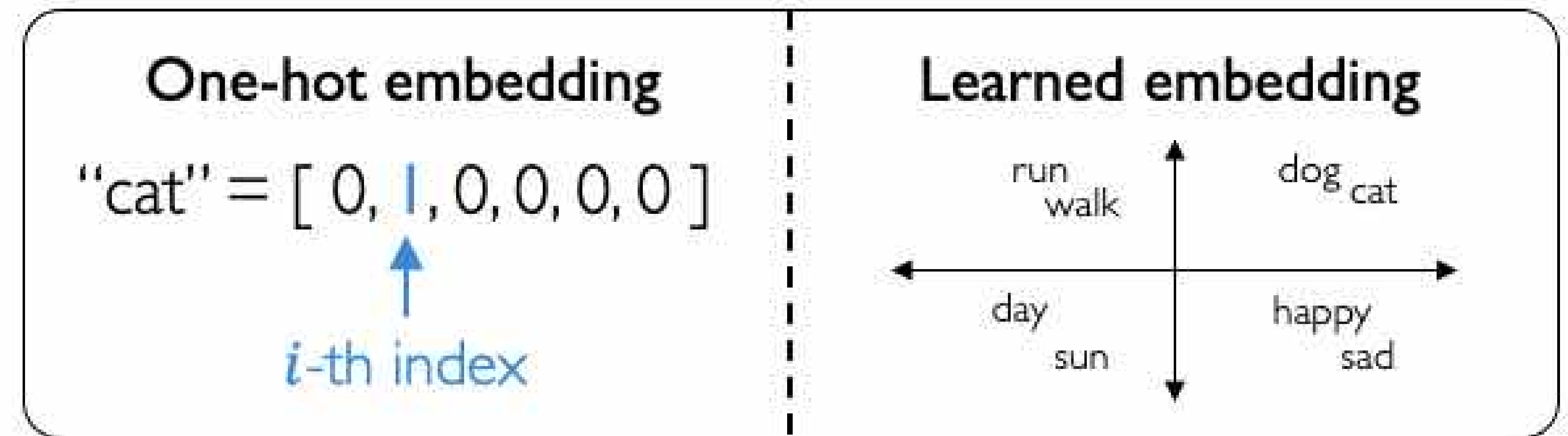

3. Embedding:
Index to fixed-sized vector

Handle Variable Sequence Lengths

The food was great

vs.

We visited a restaurant for lunch

vs.

We were hungry but cleaned the house before eating

Model Long-Term Dependencies

“**France** is where I grew up, but I now live in Boston. I speak fluent ____.”



We need information from **the distant past** to accurately predict the correct word.

Capture Differences in Sequence Order



The food was good, not bad at all.

vs.

The food was bad, not good at all.



Sequence Modeling: Design Criteria

To model sequences, we need to:

1. Handle **variable-length** sequences
2. Track **long-term** dependencies
3. Maintain information about **order**
4. **Share parameters** across the sequence

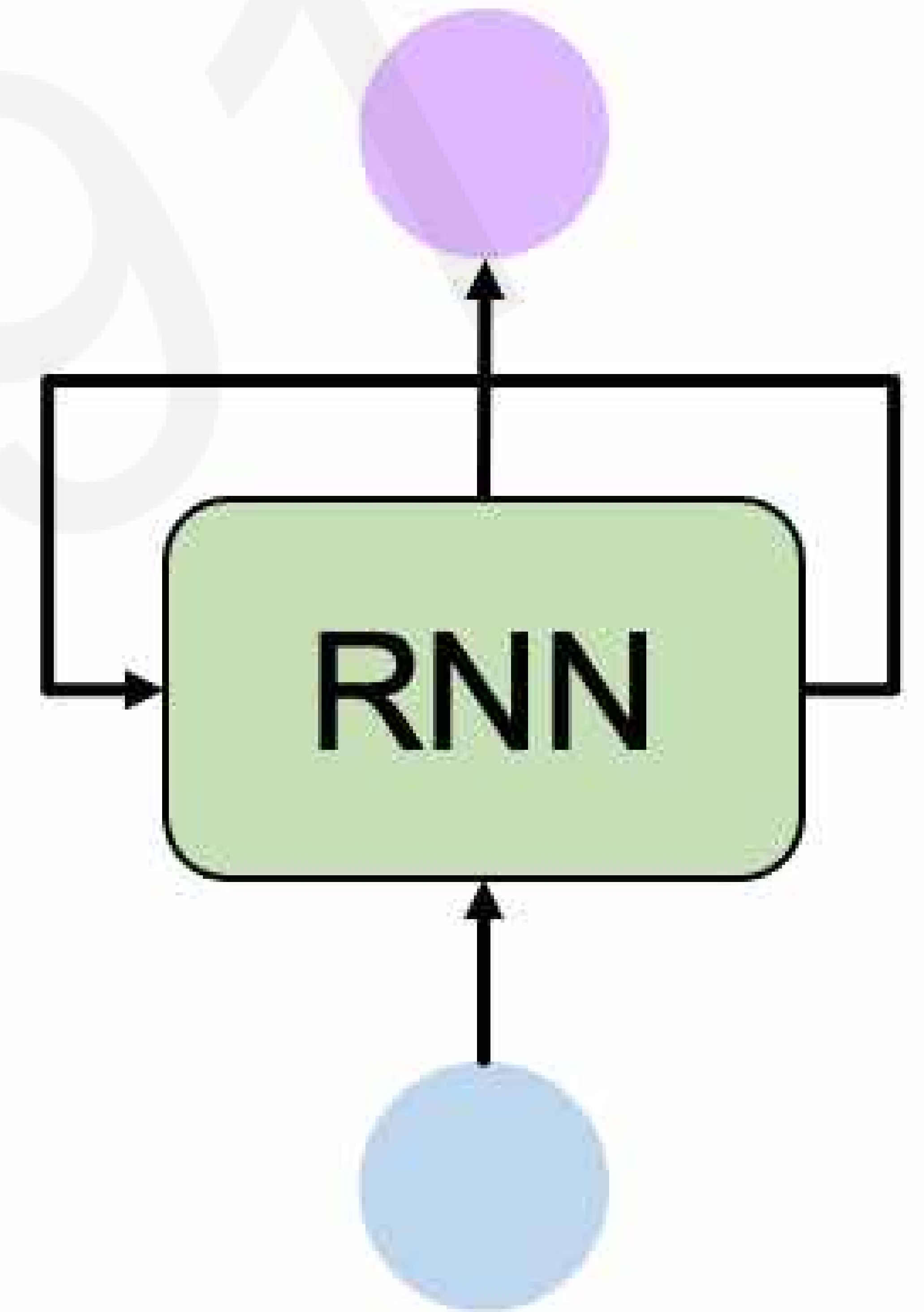

Recurrent Neural Networks (RNNs) meet these sequence modeling design criteria

Backpropagation Through Time (BPTT)

Recall: Backpropagation in Feed Forward Models

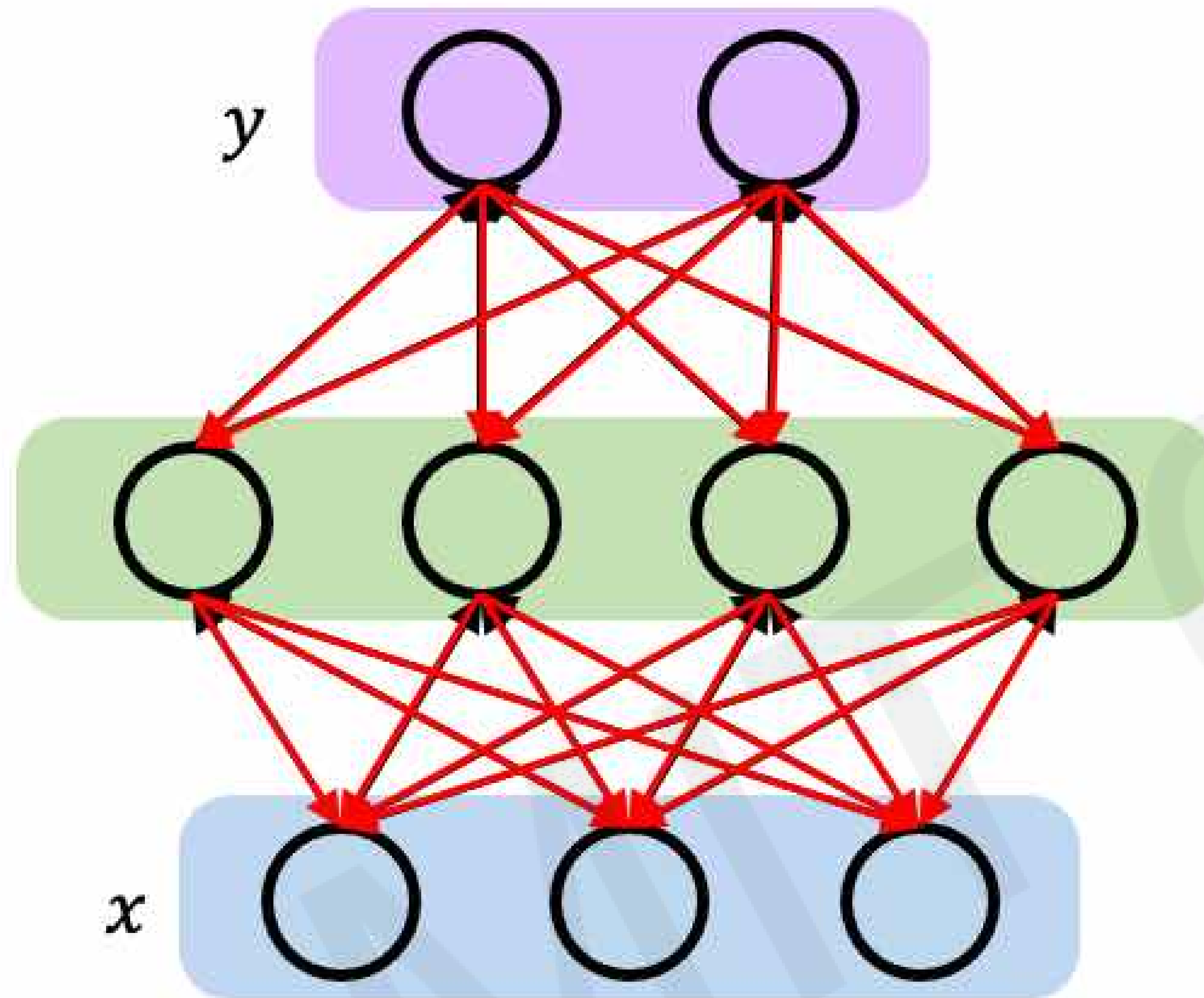

Backpropagation algorithm:

1. Take the derivative (gradient) of the loss with respect to each parameter
2. Shift parameters in order to minimize loss

RNNs: Backpropagation Through Time

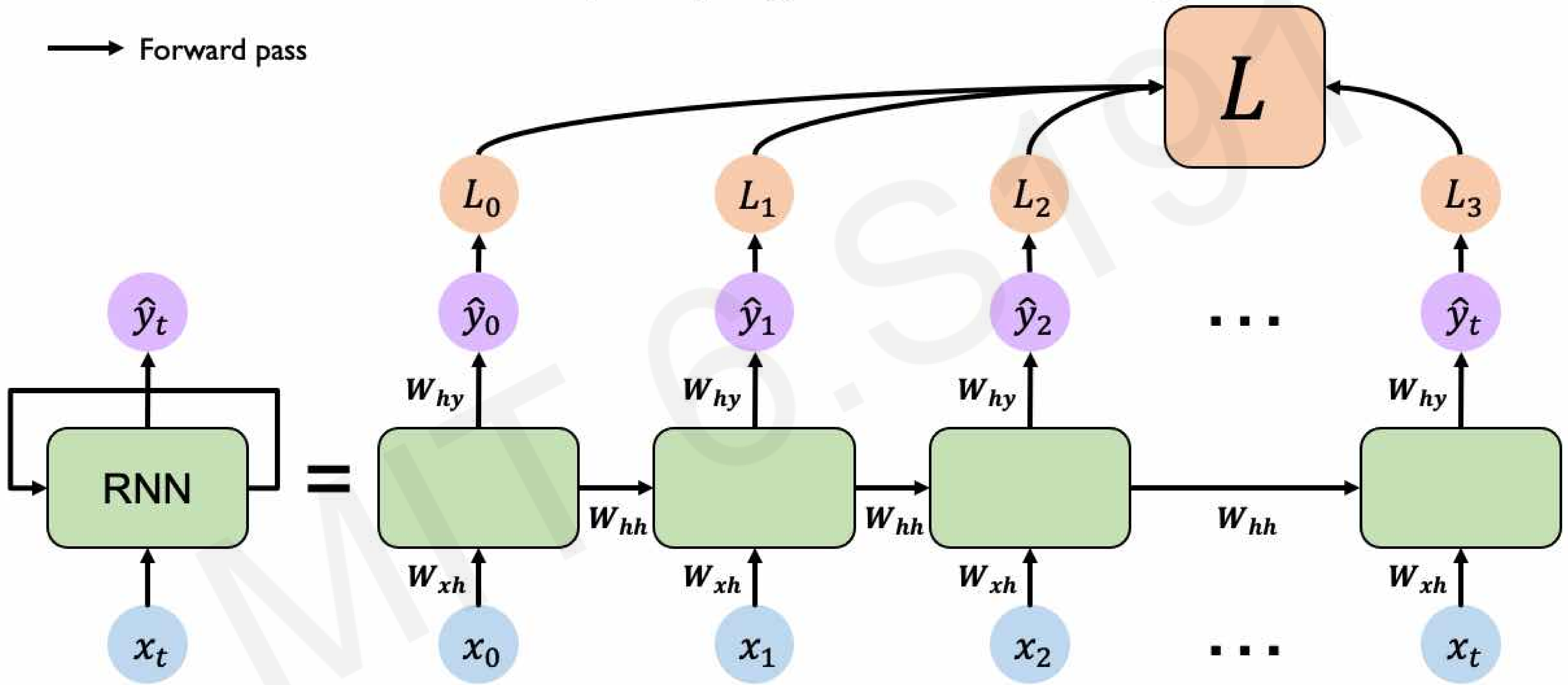

RNNs: Backpropagation Through Time

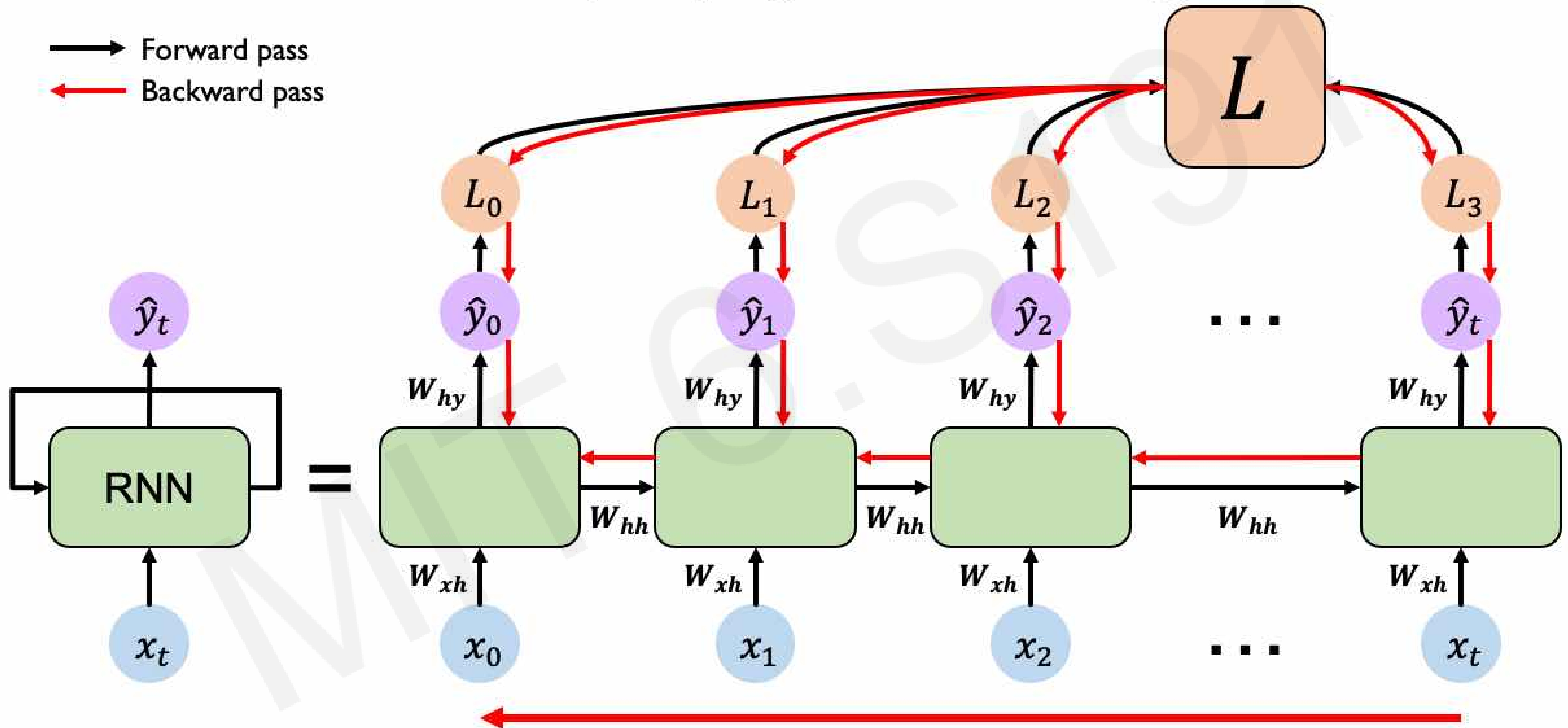

Standard RNN Gradient Flow

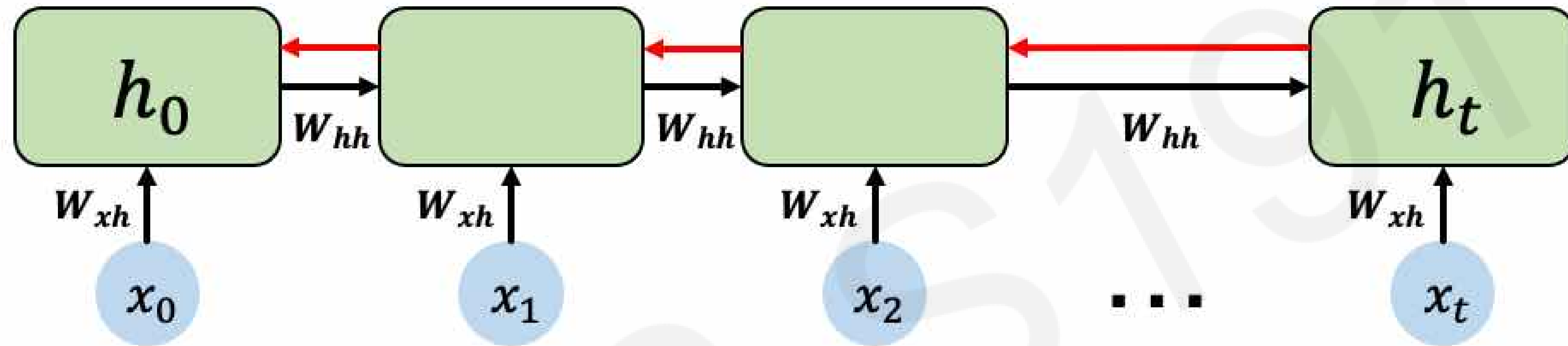

Standard RNN Gradient Flow

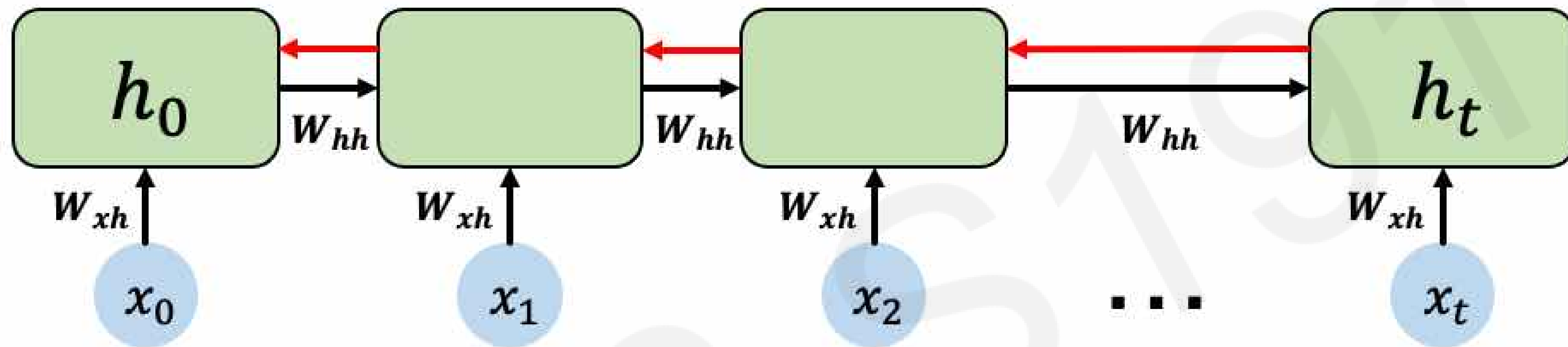

Computing the gradient wrt h_0 involves **many factors of W_{hh}** + repeated gradient computation!

Standard RNN Gradient Flow: Exploding Gradients

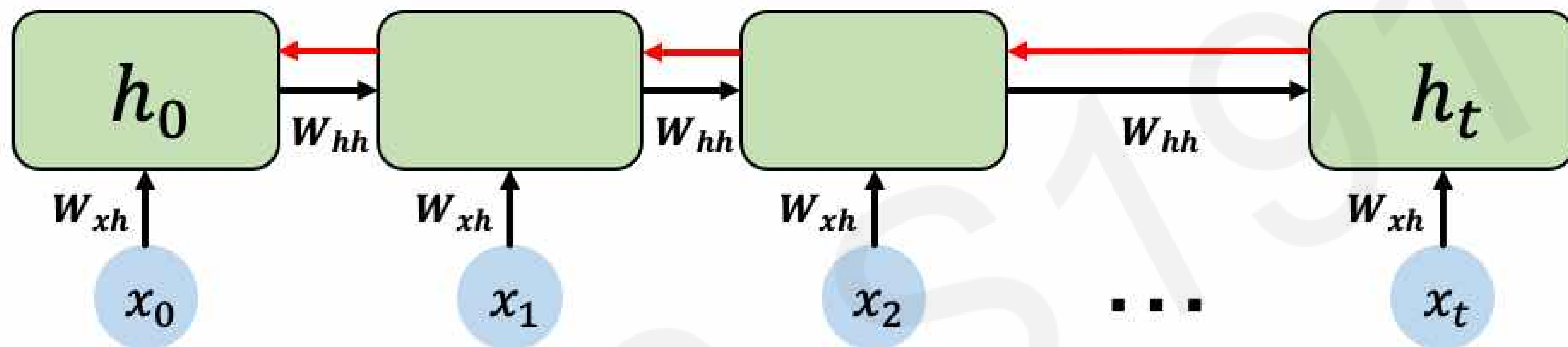

Computing the gradient wrt h_0 involves **many factors of W_{hh}** + repeated gradient computation!

Many values > 1 :
exploding gradients

Gradient clipping to
scale big gradients

Standard RNN Gradient Flow: Vanishing Gradients

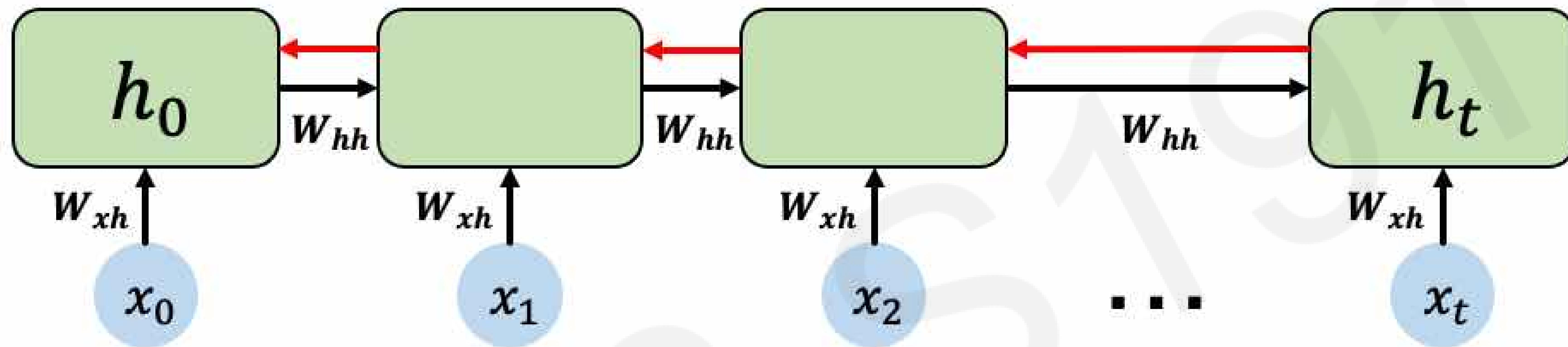

Computing the gradient wrt h_0 involves **many factors of W_{hh}** + **repeated gradient computation!**

Many values > 1 :
exploding gradients

Gradient clipping to
scale big gradients

Many values < 1 :
vanishing gradients

1. Activation function
2. Weight initialization
3. Network architecture

The Problem of Long-Term Dependencies

Why are vanishing gradients a problem?

Multiply many **small numbers** together

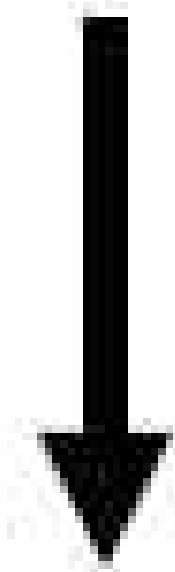

Errors due to further back time steps
have smaller and smaller gradients

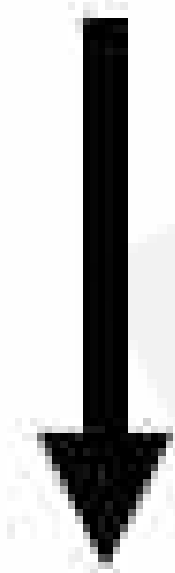

Bias parameters to capture short-term
dependencies

The Problem of Long-Term Dependencies

"The clouds are in the ____"

Why are vanishing gradients a problem?

Multiply many **small numbers** together

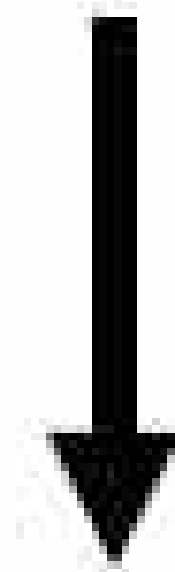

Errors due to further back time steps
have smaller and smaller gradients

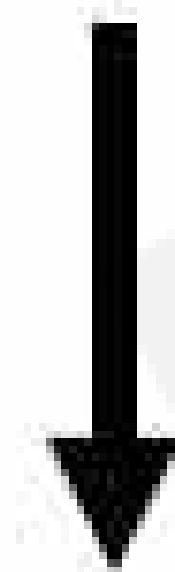

Bias parameters to capture short-term
dependencies

The Problem of Long-Term Dependencies

Why are vanishing gradients a problem?

Multiply many **small numbers** together

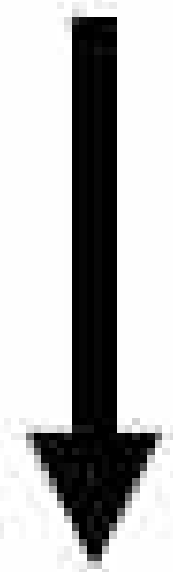

Errors due to further back time steps have smaller and smaller gradients

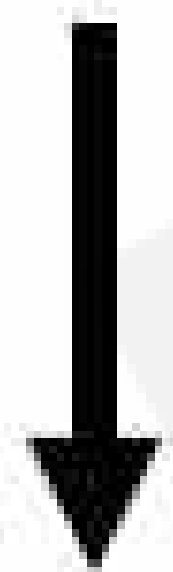

Bias parameters to capture short-term dependencies

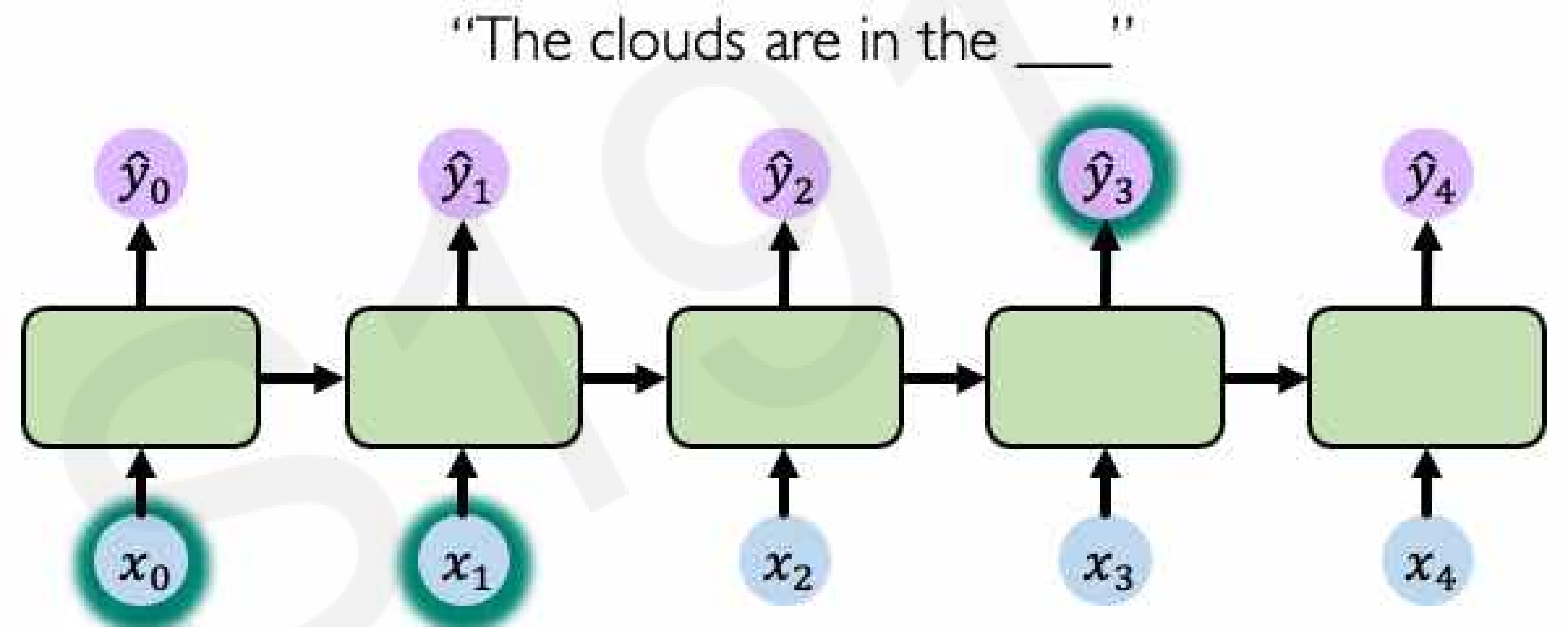

The Problem of Long-Term Dependencies

Why are vanishing gradients a problem?

Multiply many **small numbers** together

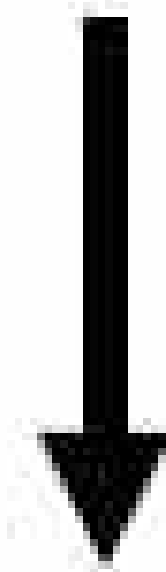

Errors due to further back time steps have smaller and smaller gradients



Bias parameters to capture short-term dependencies

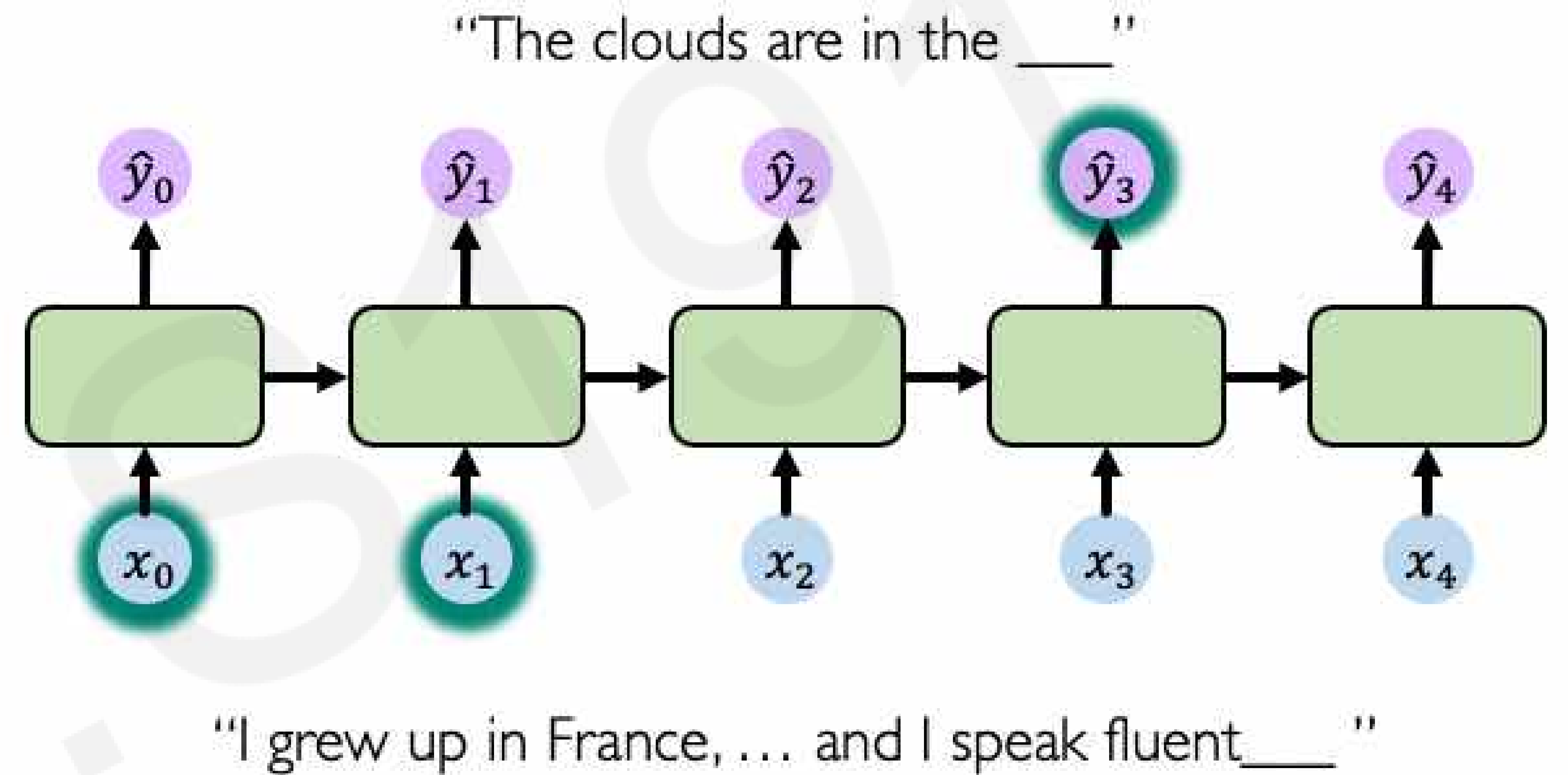

The Problem of Long-Term Dependencies

Why are vanishing gradients a problem?

Multiply many **small numbers** together

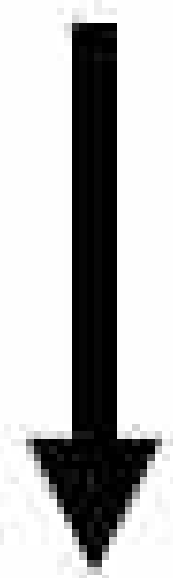

Errors due to further back time steps have smaller and smaller gradients

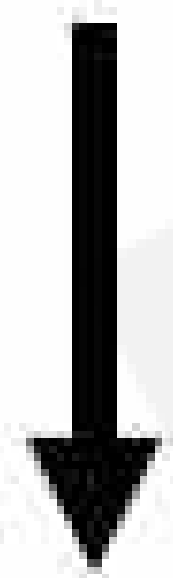

Bias parameters to capture short-term dependencies

"The clouds are in the ____"

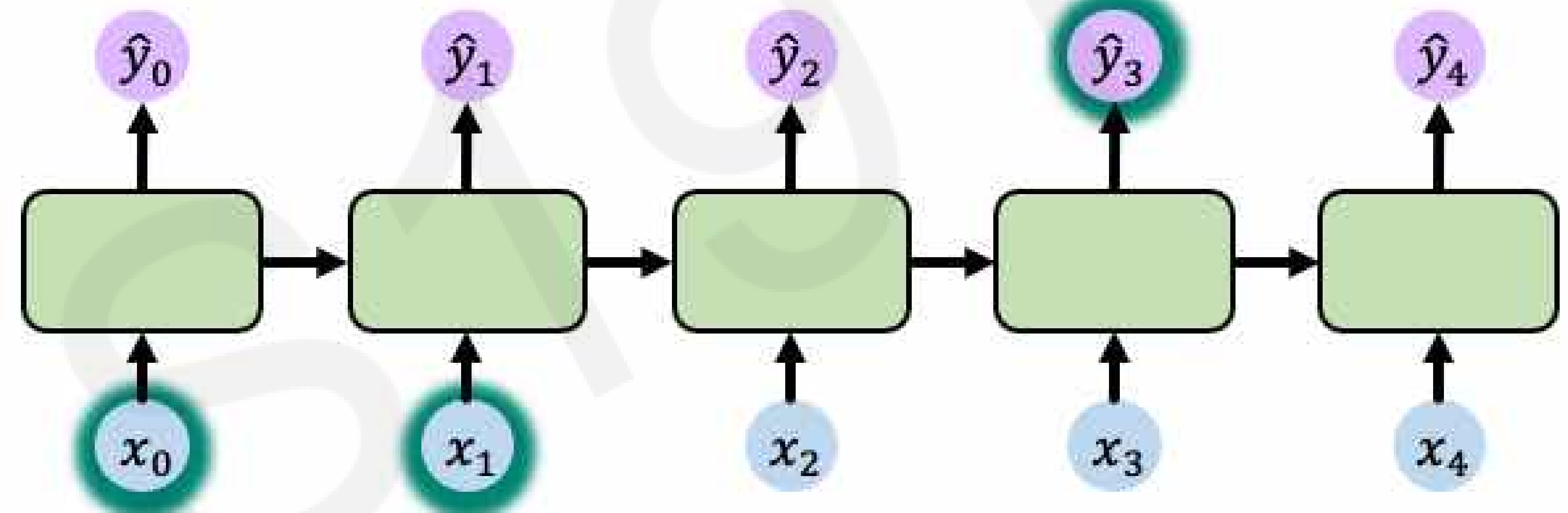

"I grew up in France, ... and I speak fluent ____"

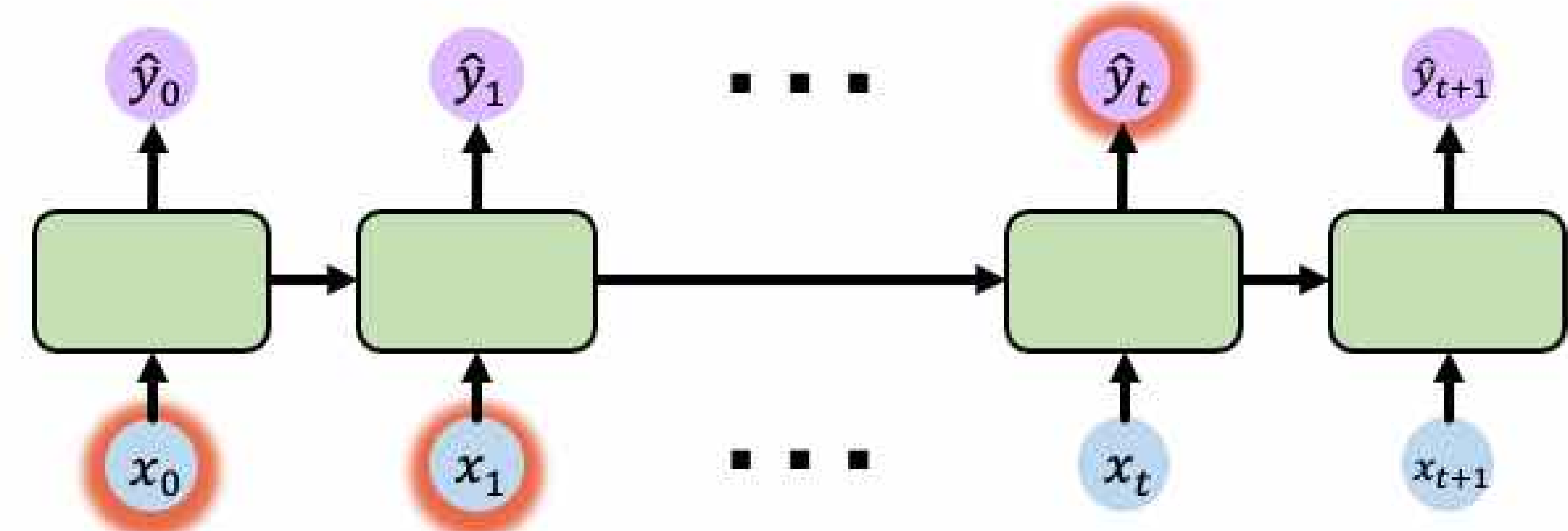

Trick #1: Activation Functions

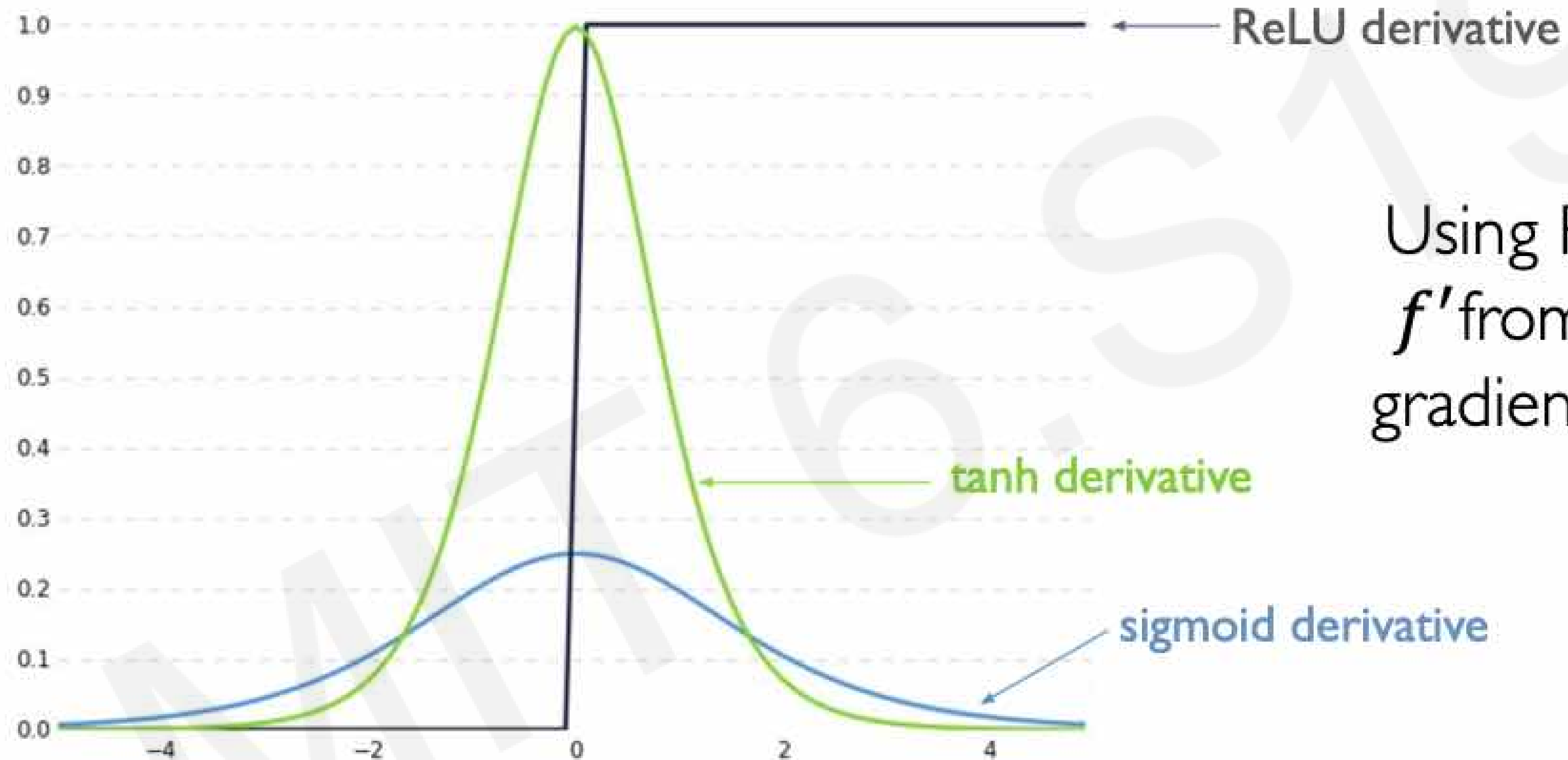

Using ReLU prevents f' from shrinking the gradients when $x > 0$

Trick #2: Parameter Initialization

Initialize **weights** to identity matrix

Initialize **biases** to zero

$$I_n = \begin{pmatrix} 1 & 0 & 0 & \cdots & 0 \\ 0 & 1 & 0 & \cdots & 0 \\ 0 & 0 & 1 & \cdots & 0 \\ \vdots & \vdots & \vdots & \ddots & \vdots \\ 0 & 0 & 0 & \cdots & 1 \end{pmatrix}$$

This helps prevent the weights from shrinking to zero.

Trick #3: Gated Cells

Idea: use **gates** to selectively **add** or **remove** information within **each recurrent unit with**

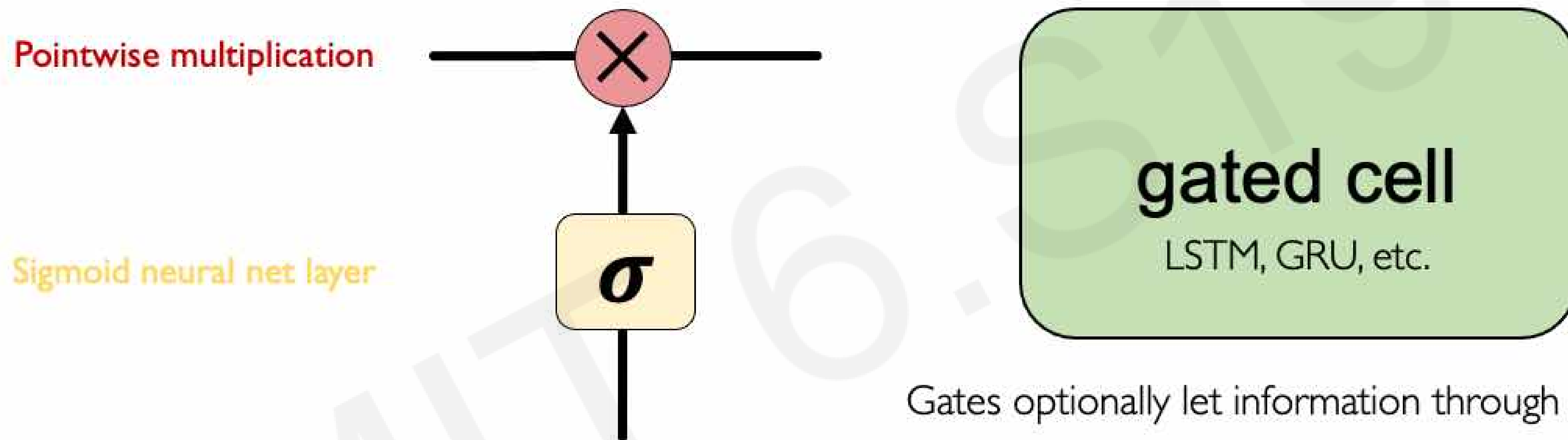

Long Short Term Memory (LSTMs) networks rely on a gated cell to track information throughout many time steps.

Long Short Term Memory (LSTMs)

Gated LSTM cells control information flow:

1) Forget 2) Store 3) Update 4) Output

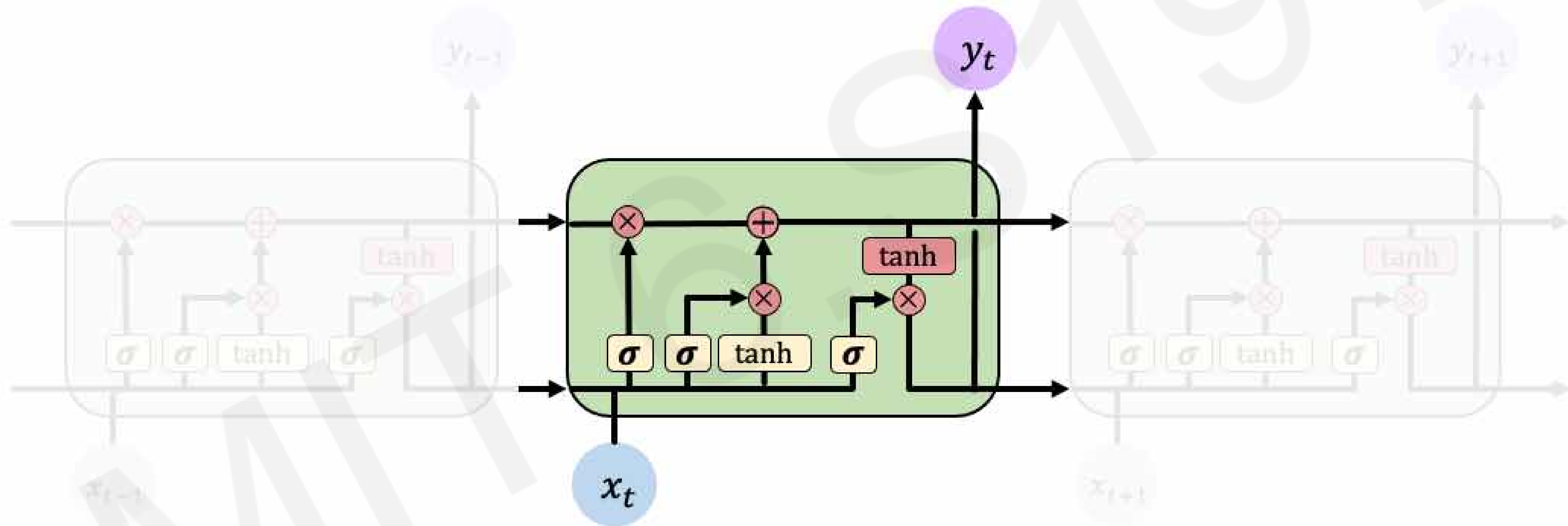

LSTM cells are able to track information throughout many timesteps

```
 tf.keras.layers.LSTM(num_units)
```

LSTMs: Key Concepts

1. Maintain a **cell state**
2. Use **gates** to control the **flow of information**
 - **Forget** gate gets rid of irrelevant information
 - **Store** relevant information from current input
 - Selectively **update** cell state
 - **Output** gate returns a filtered version of the cell state
3. Backpropagation through time with partially **uninterrupted gradient flow**

RNN Applications & Limitations

Example Task: Music Generation

Input: sheet music

Output: next character in sheet music

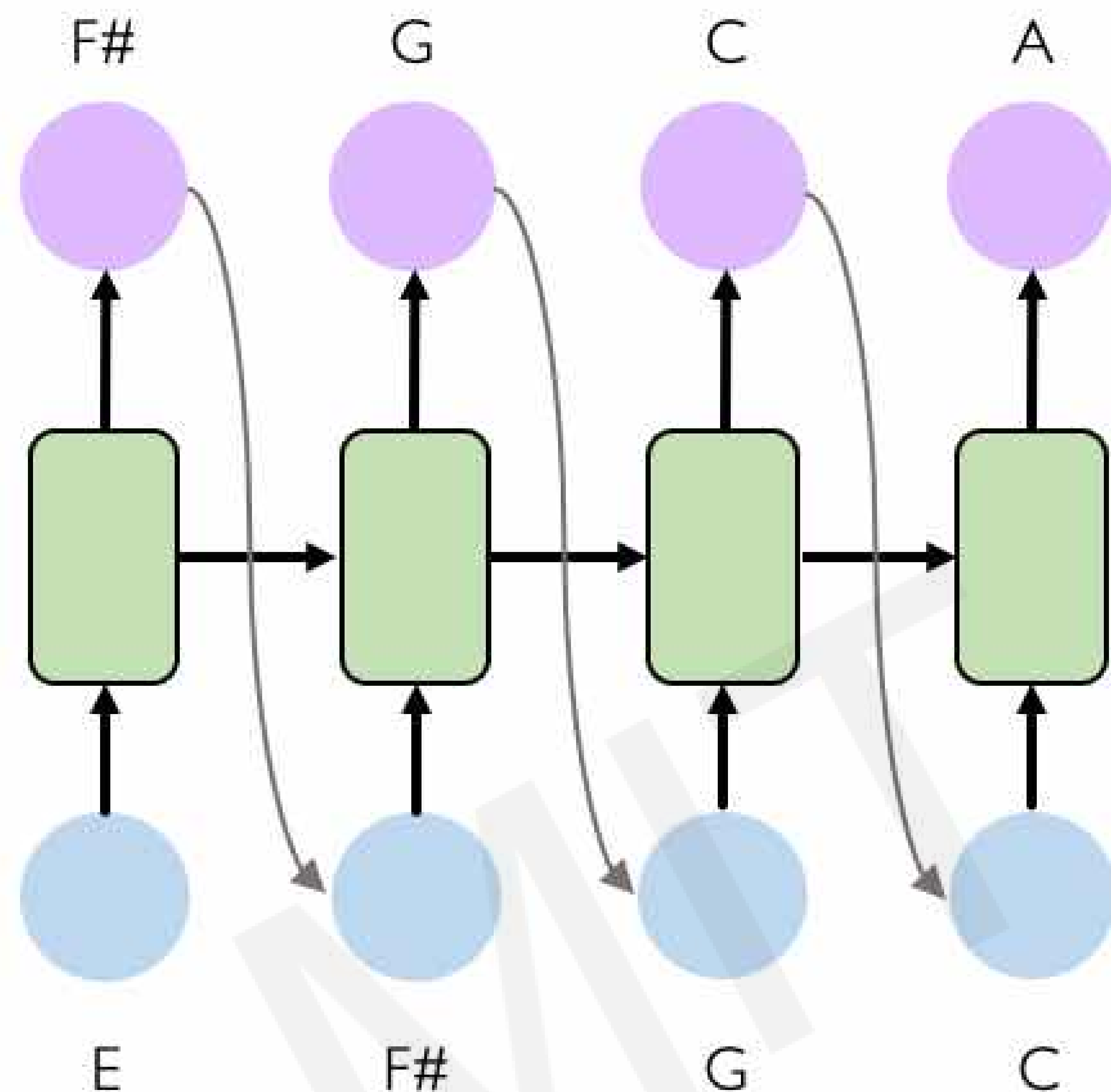

Listening to
3rd movement



6.S191 Lab!

Example Task: Sentiment Classification

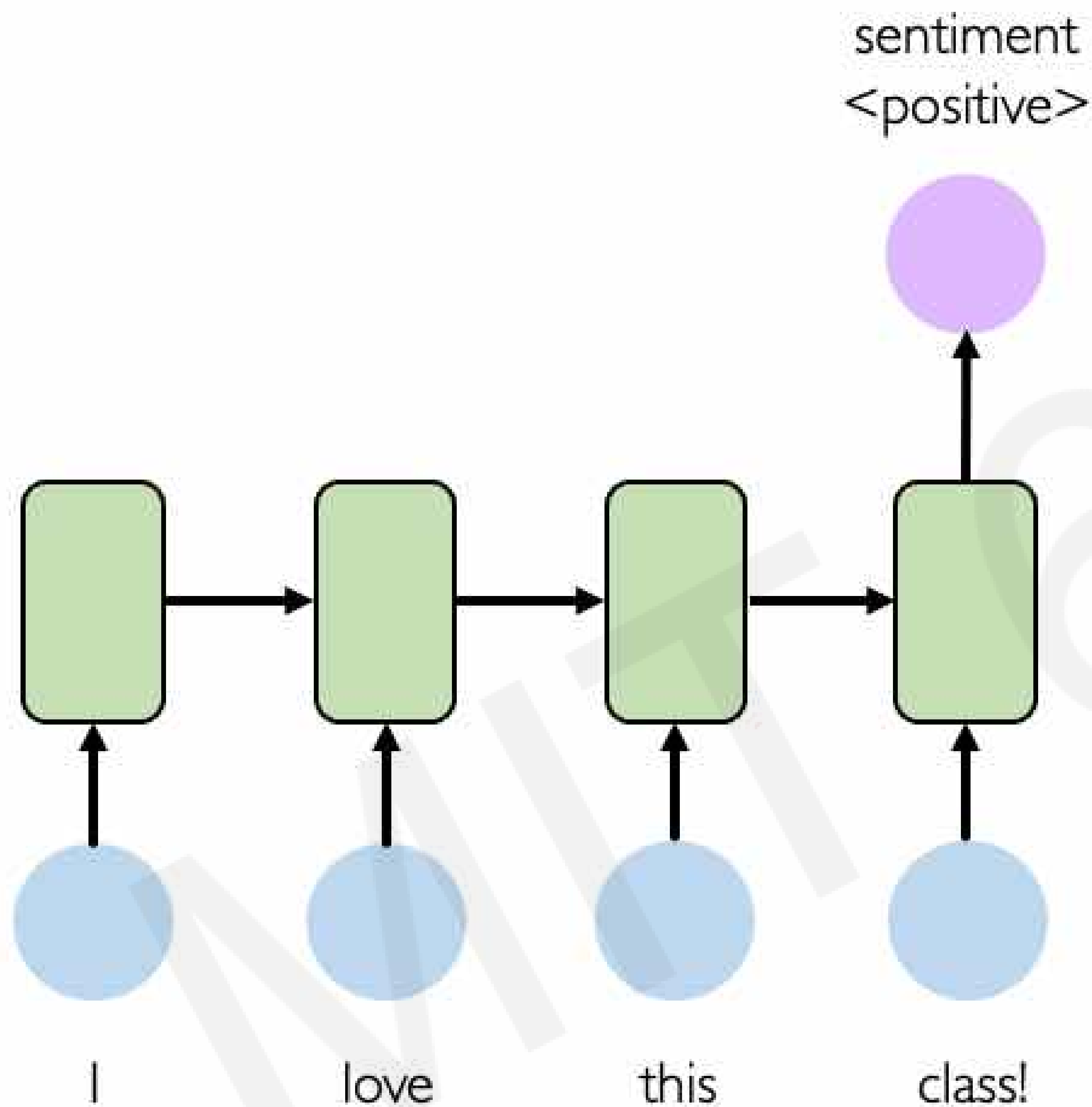

Input: sequence of words

Output: probability of having positive sentiment

 `loss = tf.nn.softmax_cross_entropy_with_logits(y, predicted)`

Example Task: Sentiment Classification

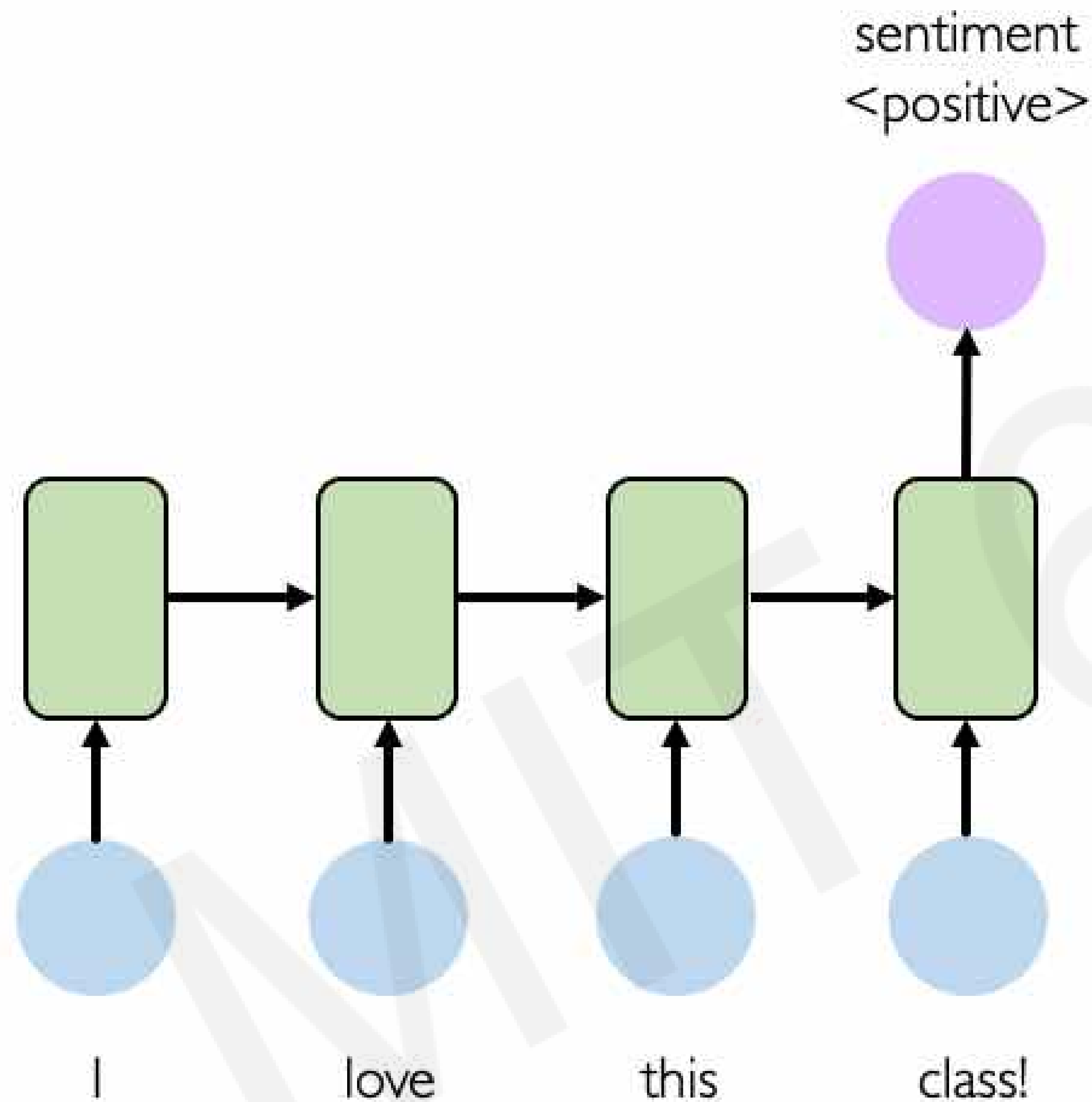

Tweet sentiment classification

 **Ivar Hagendoorn**
@IvarHagendoorn

Follow



The @MIT Introduction to #DeepLearning is definitely one of the best courses of its kind currently available online introtodeeplearning.com

12:45 PM - 12 Feb 2018

 **Angels-Cave**
@AngelsCave

Follow

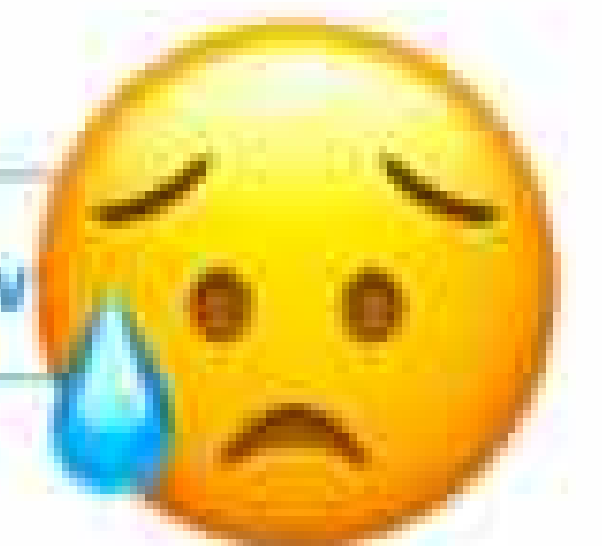

Replying to @Kazuki2048



I wouldn't mind a bit of snow right now. We haven't had any in my bit of the Midlands this winter! :(

2:19 AM - 25 Jan 2019

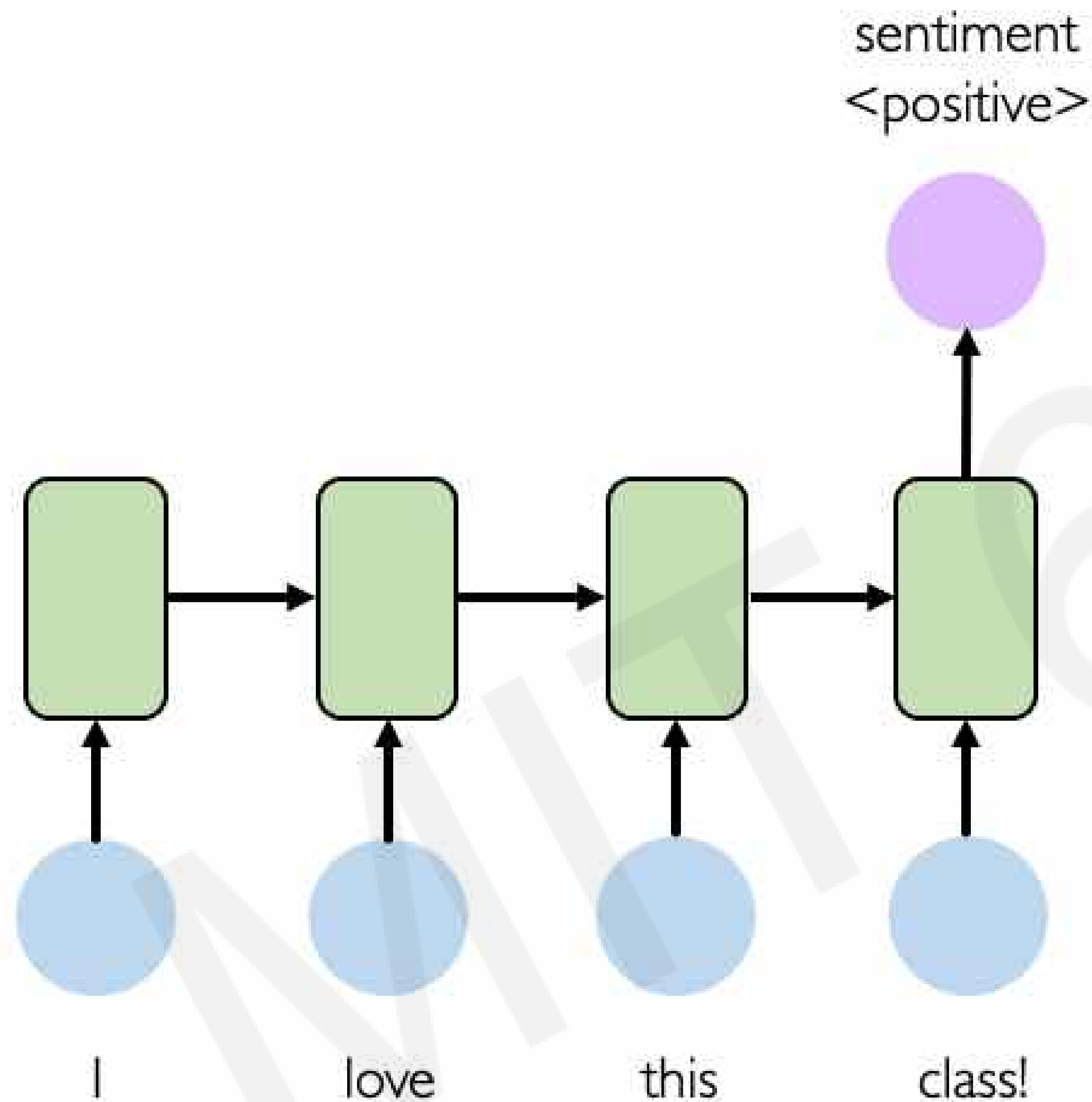
Limitations of Recurrent Models

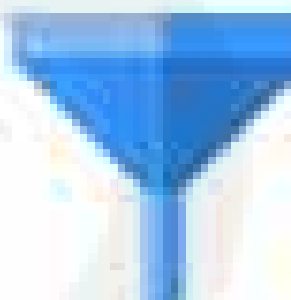

Limitations of RNNs

-  Encoding bottleneck
-  Slow, no parallelization
-  Not long memory

Goal of Sequence Modeling

RNNs: recurrence to model sequence dependencies

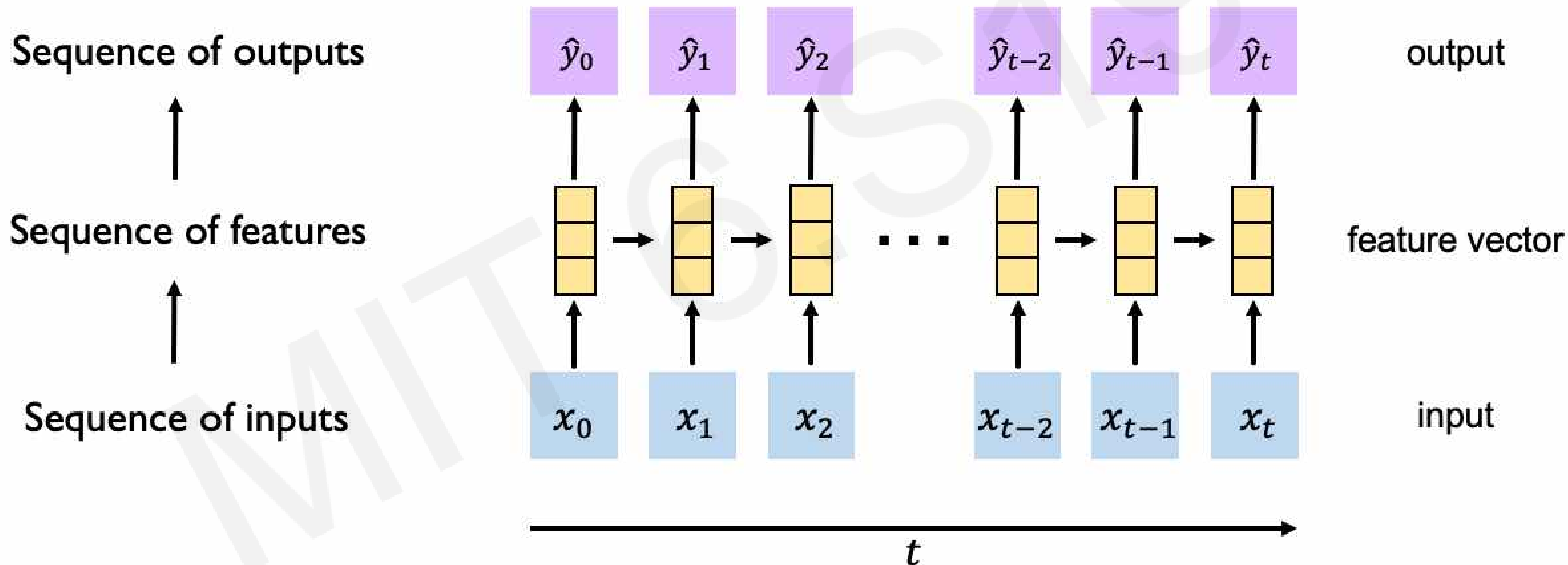

Goal of Sequence Modeling

RNNs: recurrence to model sequence dependencies

Limitations of RNNs



Encoding bottleneck



Slow, no parallelization

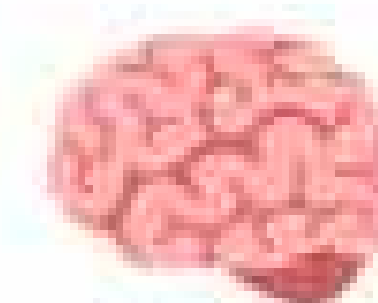

Not long memory

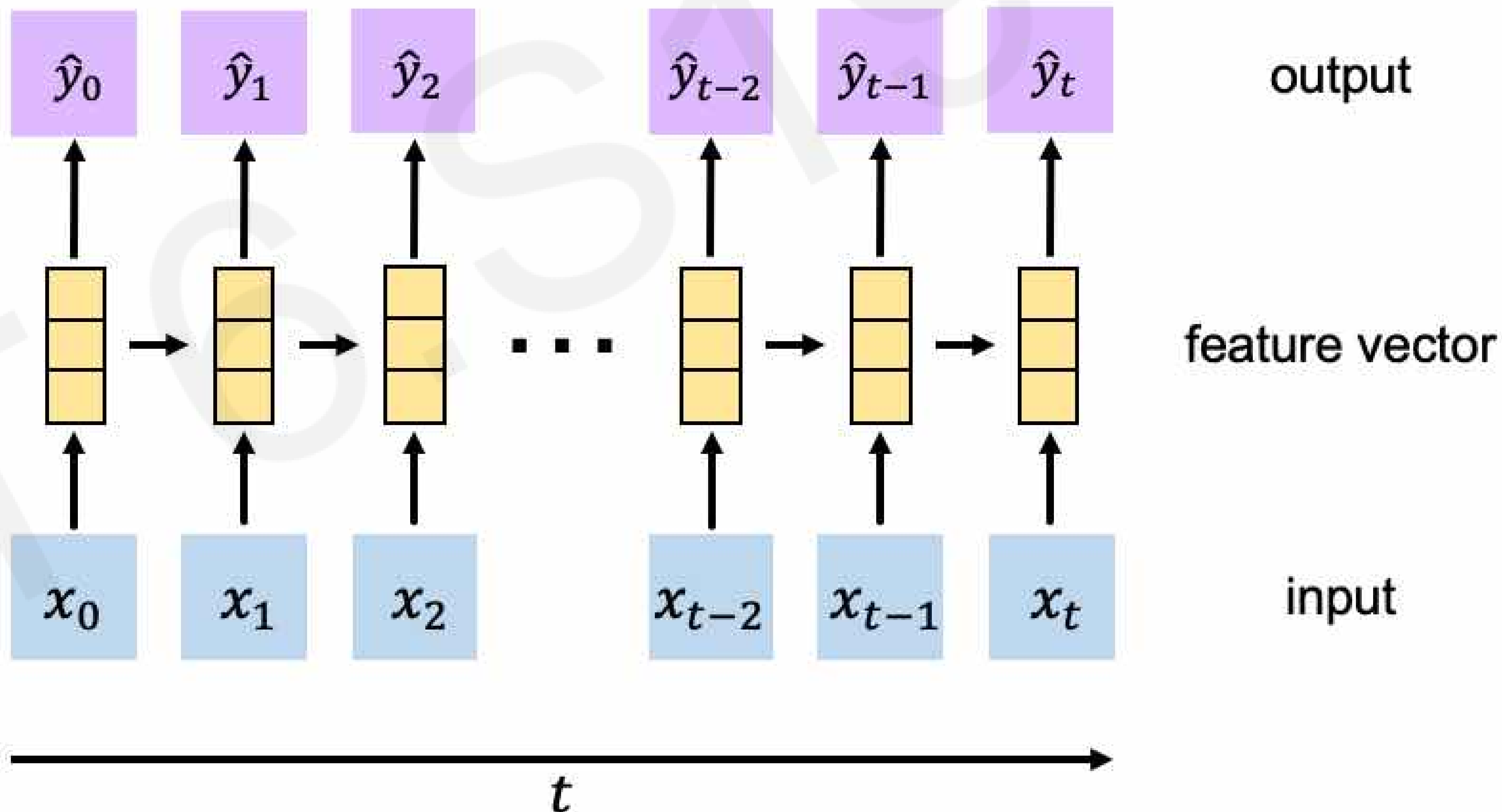

Goal of Sequence Modeling

Can we eliminate the need for recurrence entirely?

Desired Capabilities

 Continuous stream

 Parallelization

 Long memory

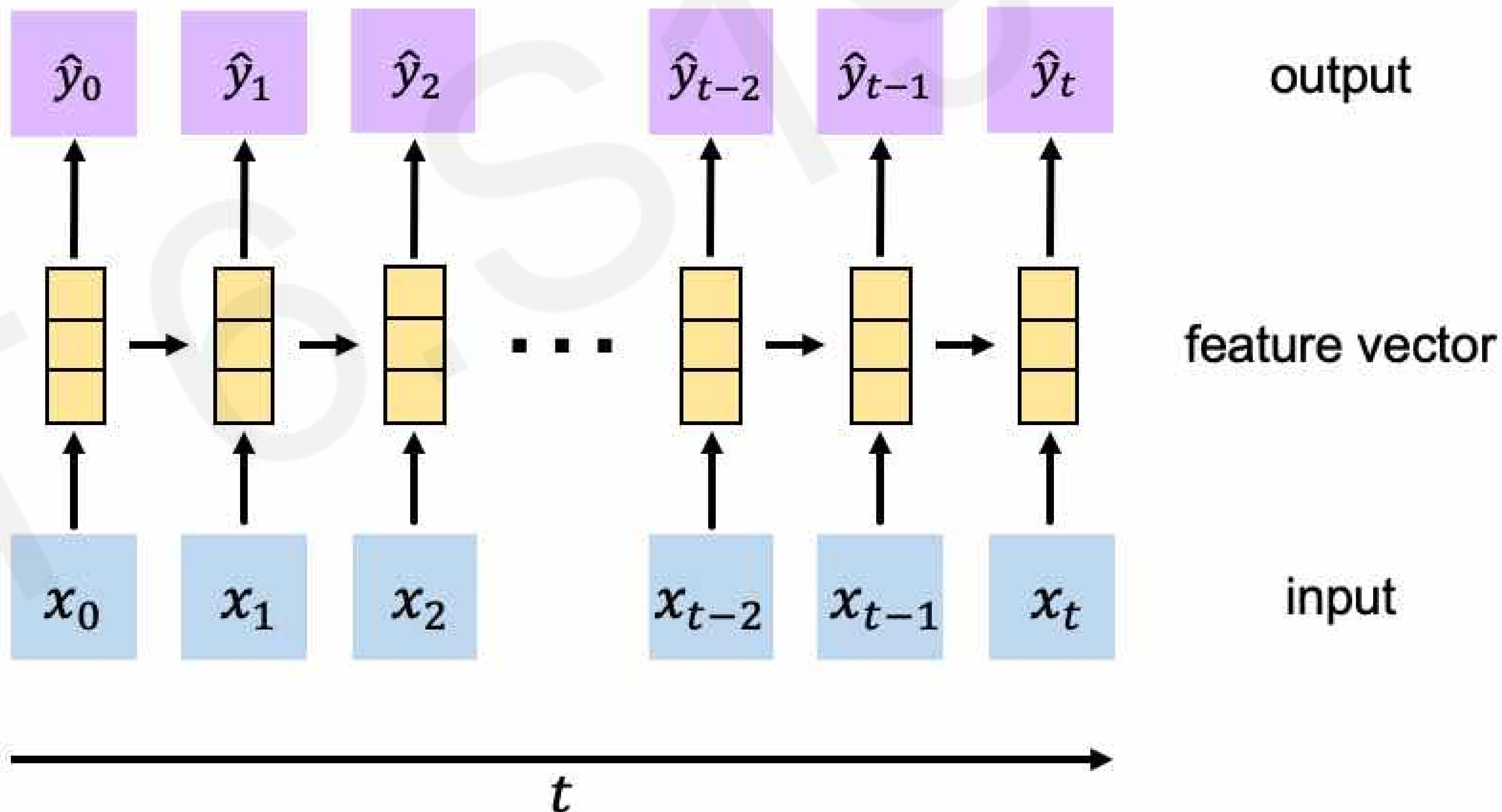

Goal of Sequence Modeling

Can we eliminate the need for recurrence entirely?

Desired Capabilities

 Continuous stream

 Parallelization

 Long memory

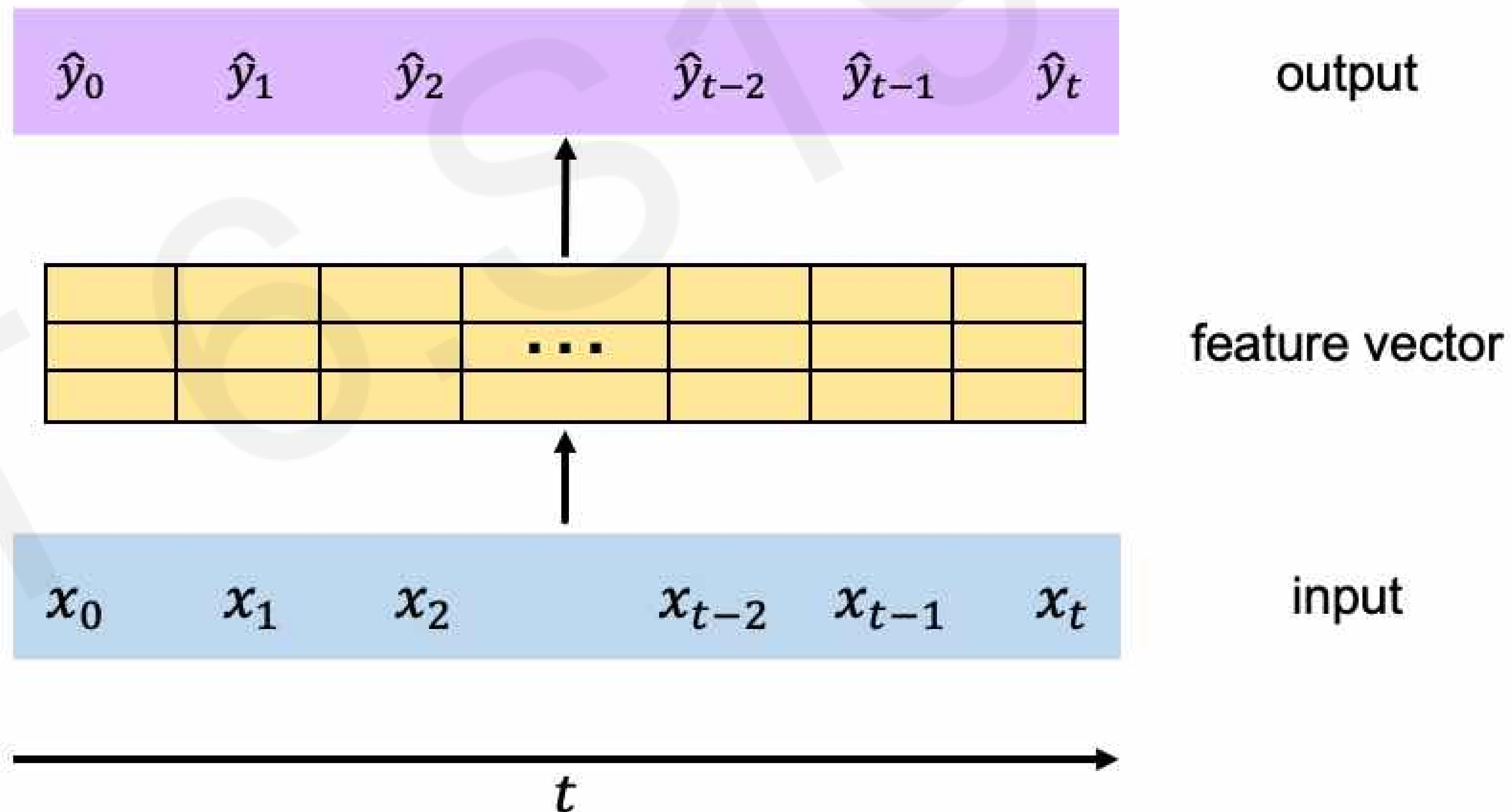

Goal of Sequence Modeling

Idea 1: Feed everything into dense network

- ✓ No recurrence
- ✗ Not scalable
- ✗ No order
- ✗ No long memory

 Idea: Identify and attend to what's important

Can we eliminate the need for recurrence entirely?

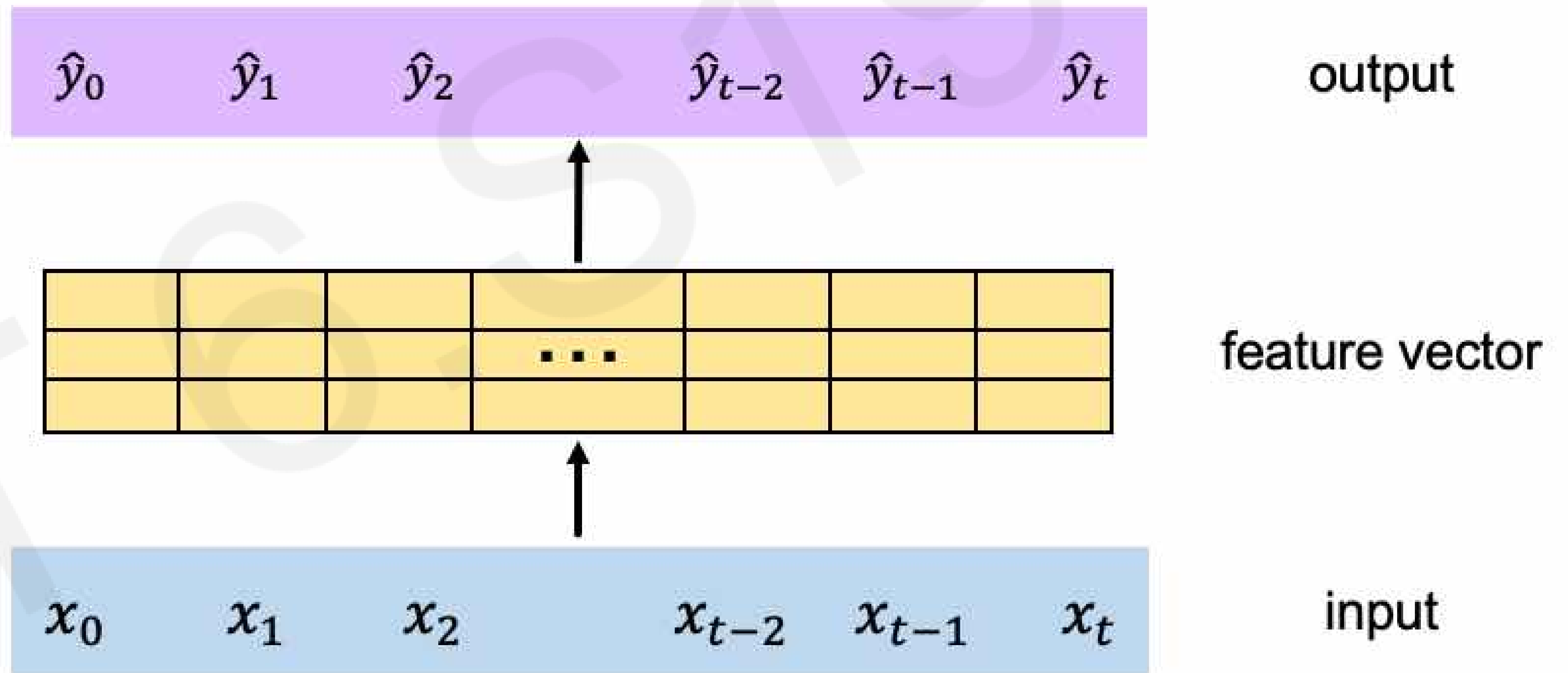

Attention Is All You Need

Intuition Behind Self-Attention

Attending to the most important parts of an input.

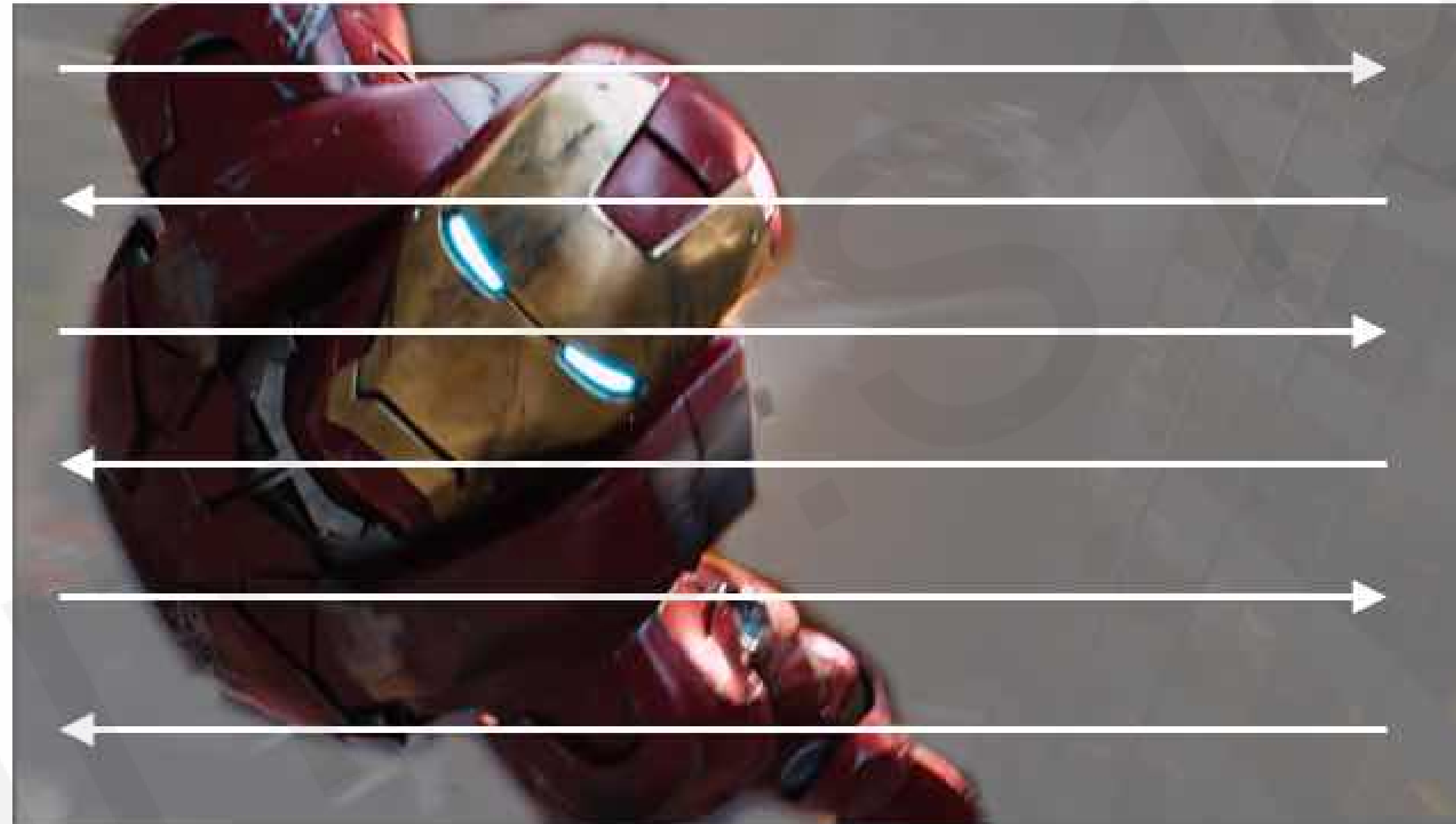

1. Identify which parts to attend to
2. Extract the features with high attention

Similar to a search problem!

A Simple Example: Search



How can I learn
more about
neural networks?



Understanding Attention with Search

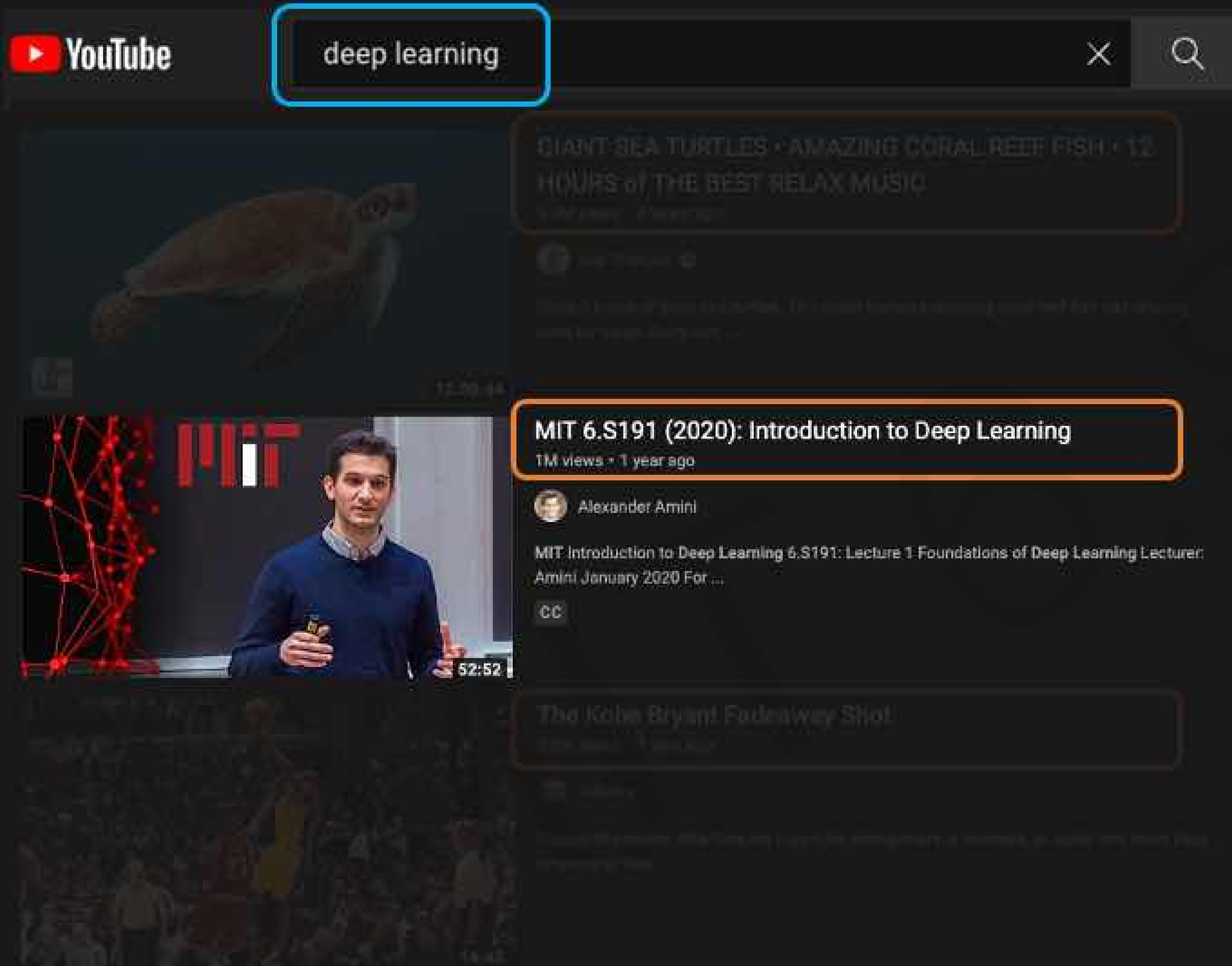

Query (Q)

Key (K_1)

Key (K_2)

Key (K_3)

How similar is the key to the query?

1. **Compute attention mask:** how similar is each key to the desired query?

Understanding Attention with Search

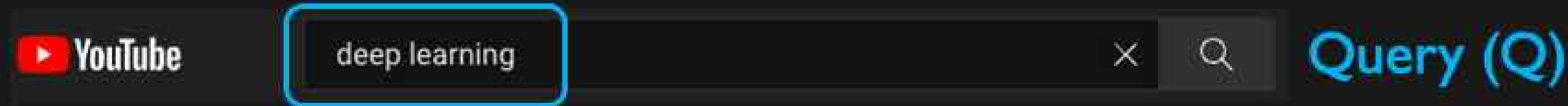

Query (Q)

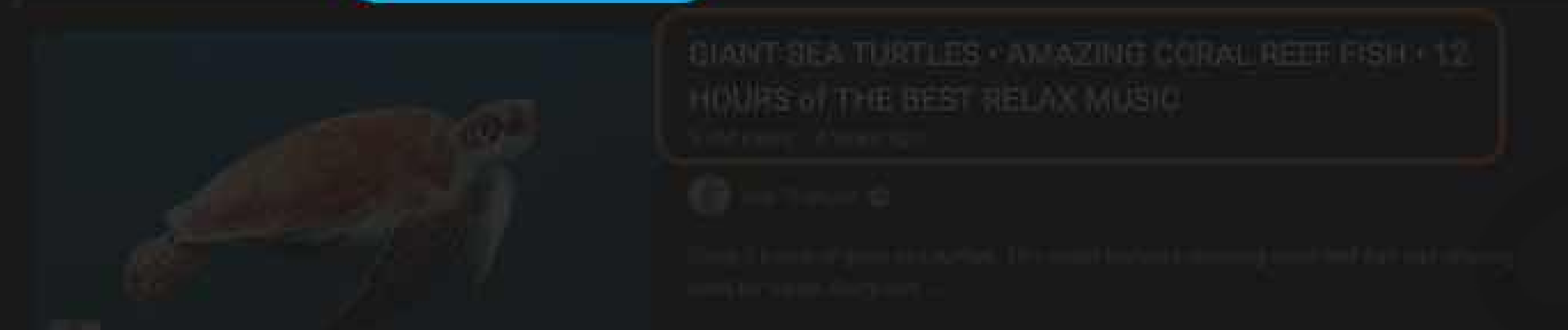

Key (K_1)

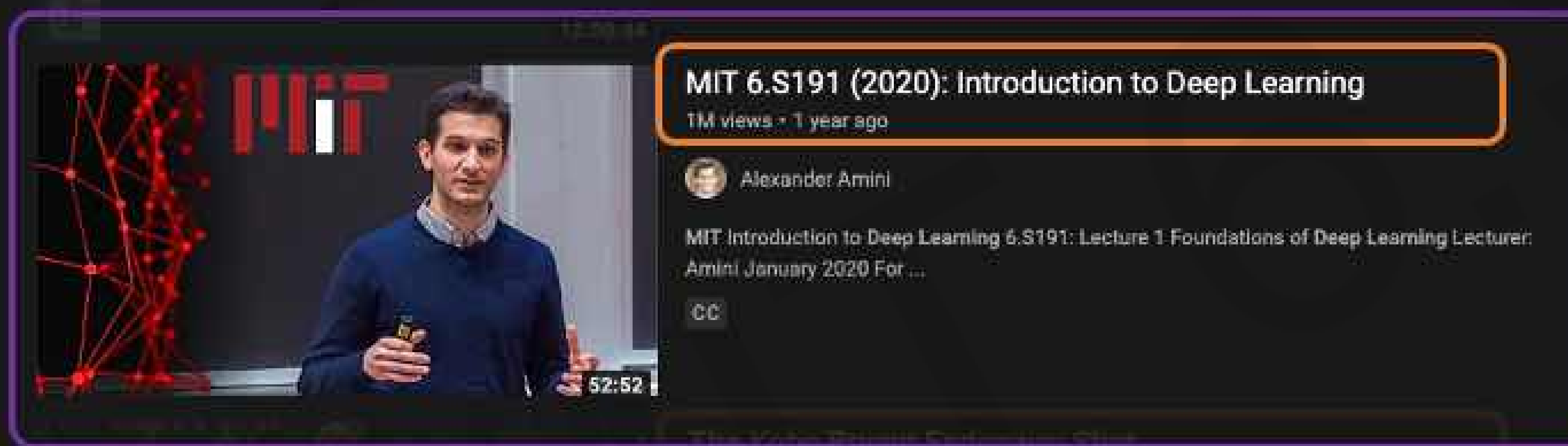

Key (K_2)

Value (V)

Key (K_3)

2. Extract values based on attention:
Return the values highest attention

Learning Self-Attention with Neural Networks

Goal: identify and attend to most important features in input.

1. Encode **position** information
2. Extract query, key, value for search
3. Compute attention weighting
4. Extract features with high attention



Data is fed in all at once! Need to encode position information to understand order.

Learning Self-Attention with Neural Networks

Goal: identify and attend to most important features in input.

1. Encode **position** information
2. Extract query, key, value for search
3. Compute attention weighting
4. Extract features with high attention

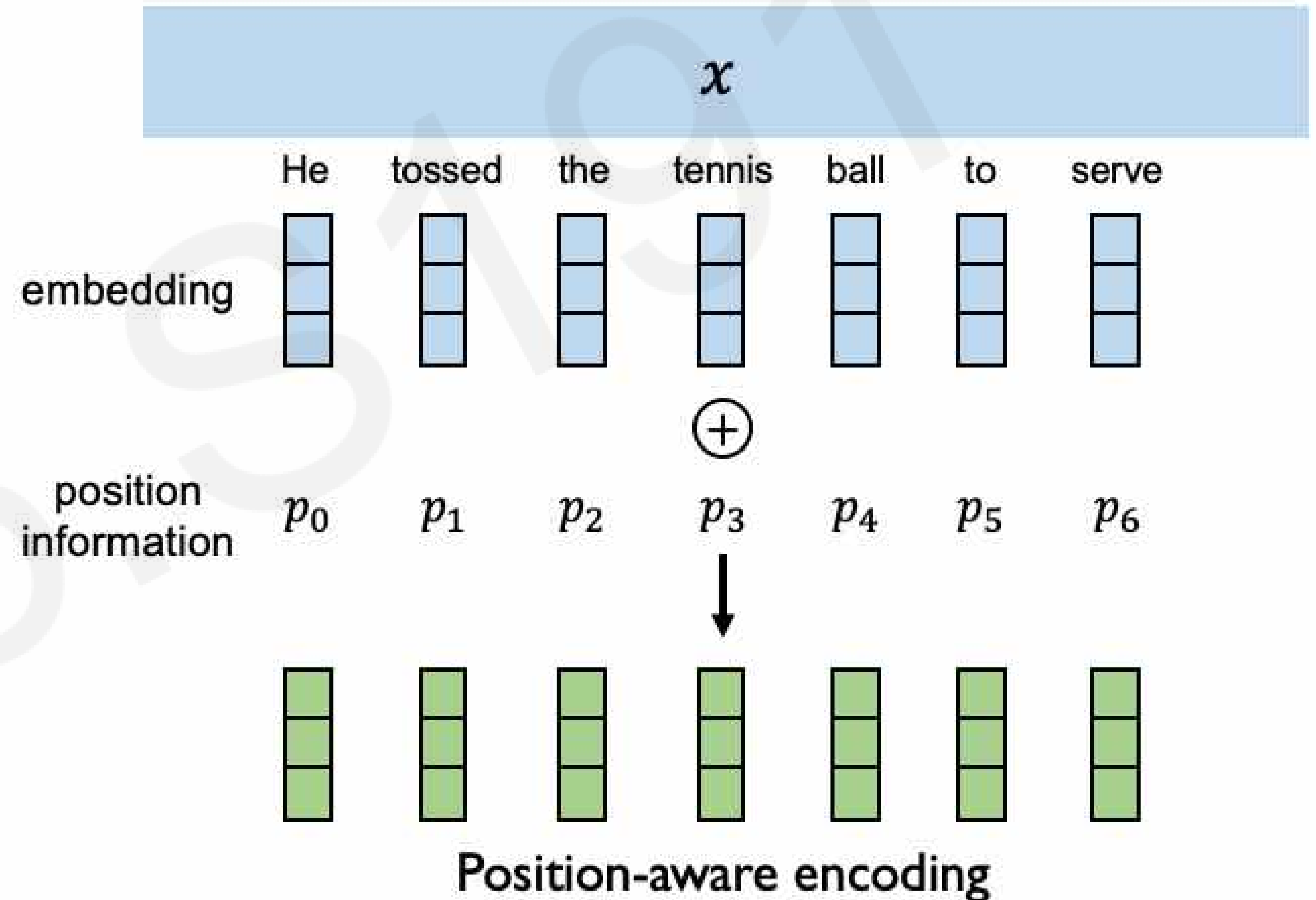

Data is fed in all at once! Need to encode position information to understand order.

Learning Self-Attention with Neural Networks

Goal: identify and attend to most important features in input.

1. Encode **position** information
2. Extract **query, key, value** for search
3. Compute attention weighting
4. Extract features with high attention

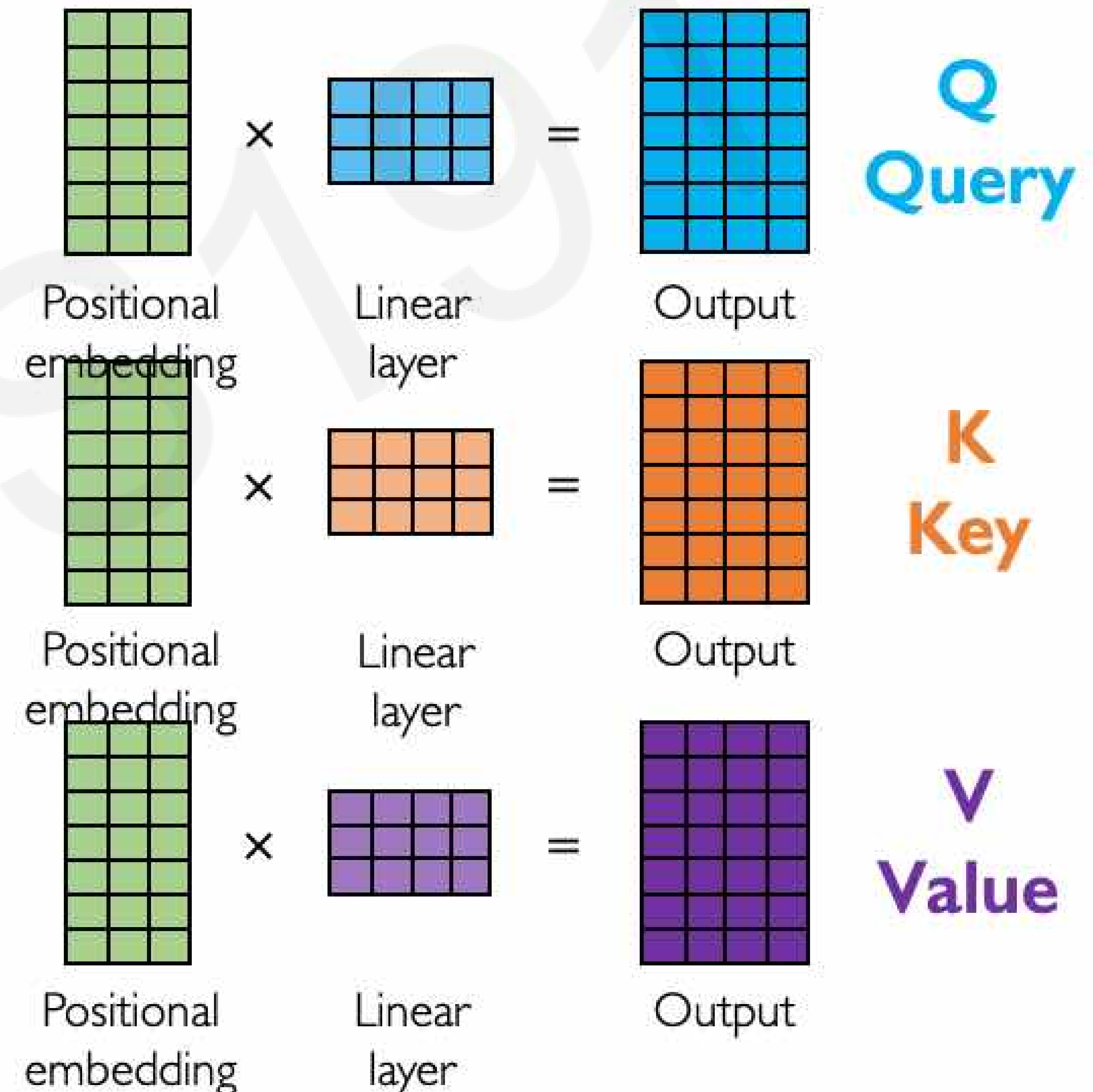

Learning Self-Attention with Neural Networks

Goal: identify and attend to most important features in input.

1. Encode **position** information
2. Extract **query, key, value** for search
3. Compute **attention weighting**
4. Extract features with high attention

Attention score: compute pairwise similarity between each **query** and **key**

How to compute similarity between two sets of features?

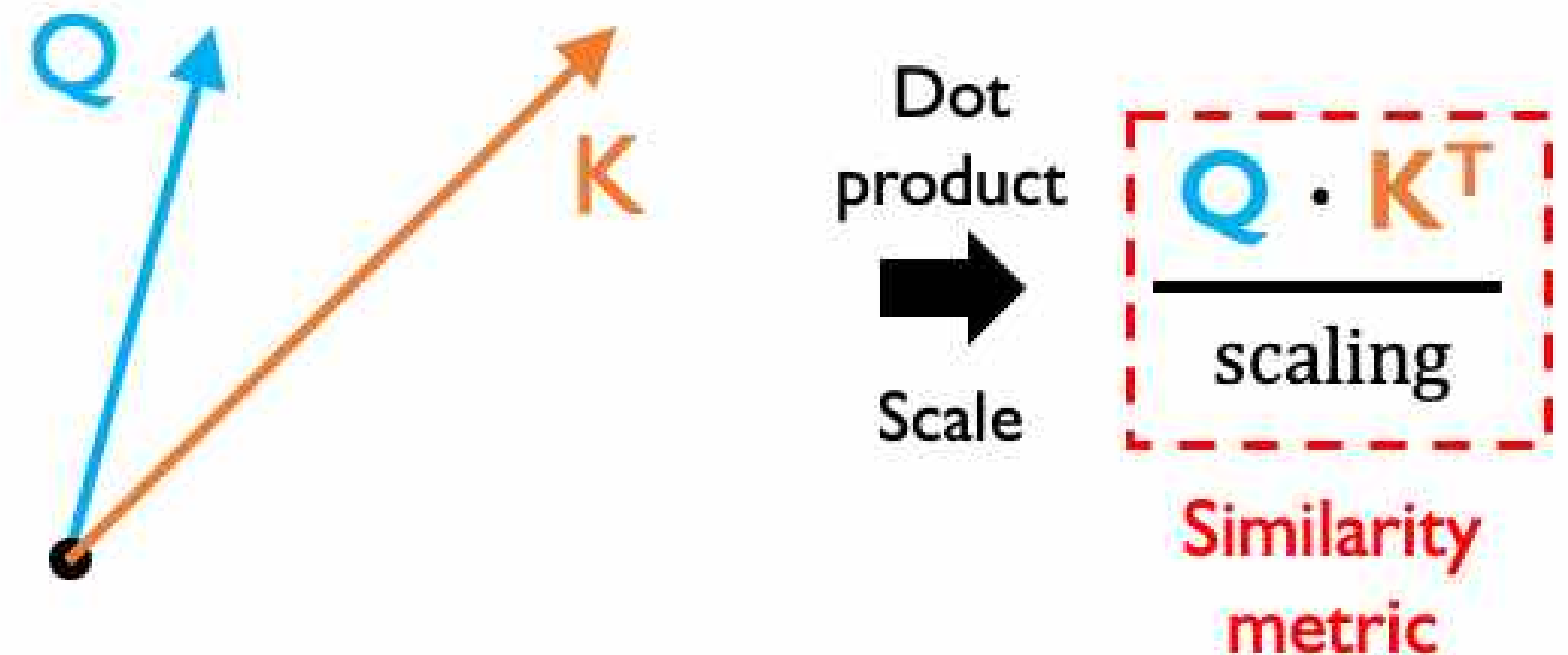

Also known as the “cosine similarity”

Learning Self-Attention with Neural Networks

Goal: identify and attend to most important features in input.

1. Encode **position** information
2. Extract **query, key, value** for search
3. Compute **attention weighting**
4. Extract features with high attention

Attention score: compute pairwise similarity between each **query** and **key**

How to compute similarity between two sets of features?

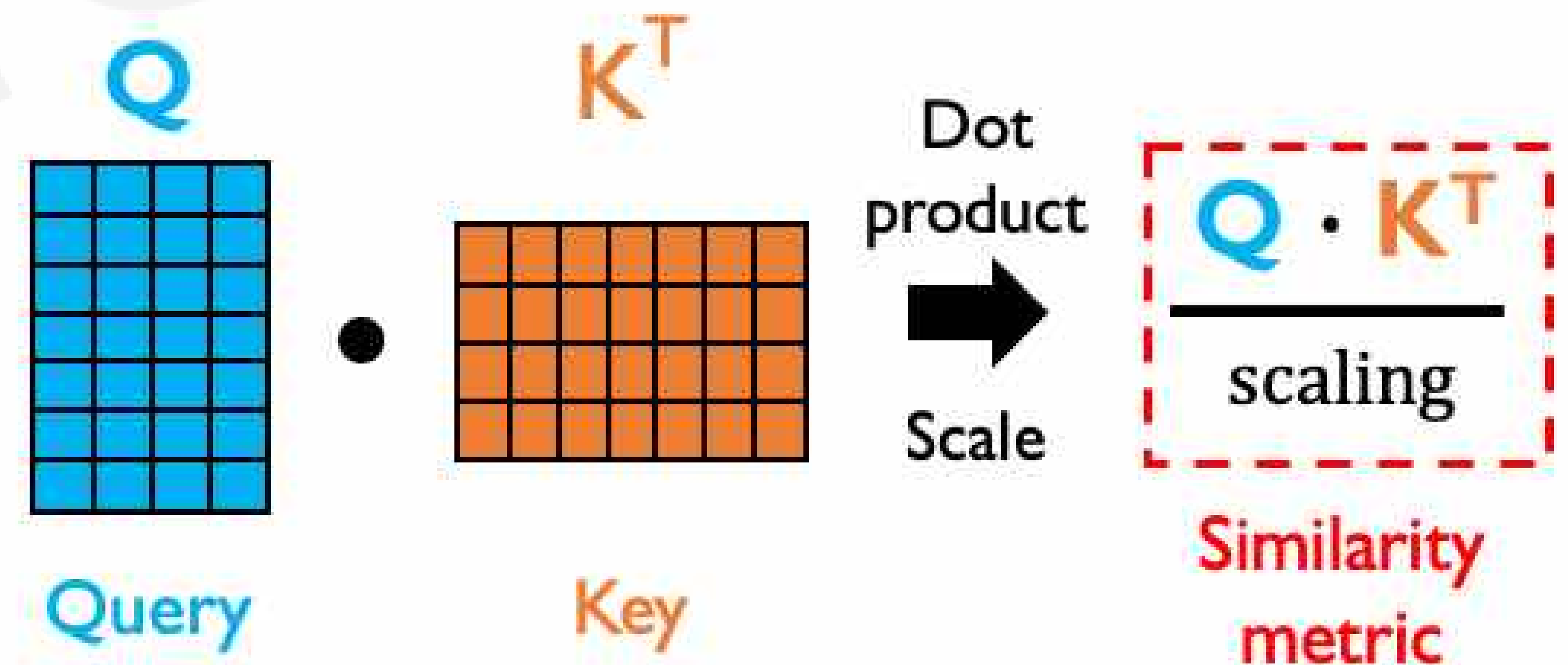

Also known as the "cosine similarity"

Learning Self-Attention with Neural Networks

Goal: identify and attend to most important features in input.

1. Encode **position** information
2. Extract **query, key, value** for search
3. Compute **attention weighting**
4. Extract features with high attention

Attention weighting: where to attend to!
How similar is the key to the query?

	He	tossed	the	tennis	ball	to	serve
He	1	0	0	0	0	0	0
tossed	0	1	0	0	1	0	0
the	0	0	1	0	0	0	0
tennis	0	0	0	1	1	0	1
ball	0	1	0	1	1	0	0
to	0	0	0	0	0	1	0
serve	0	0	0	1	0	0	1

$$\text{softmax} \left(\frac{Q \cdot K^T}{\text{scaling}} \right)$$

Attention weighting

Learning Self-Attention with Neural Networks

Goal: identify and attend to most important features in input.

1. Encode **position** information
2. Extract **query, key, value** for search
3. Compute **attention weighting**
4. Extract **features with high attention**

Last step: self-attend to extract features

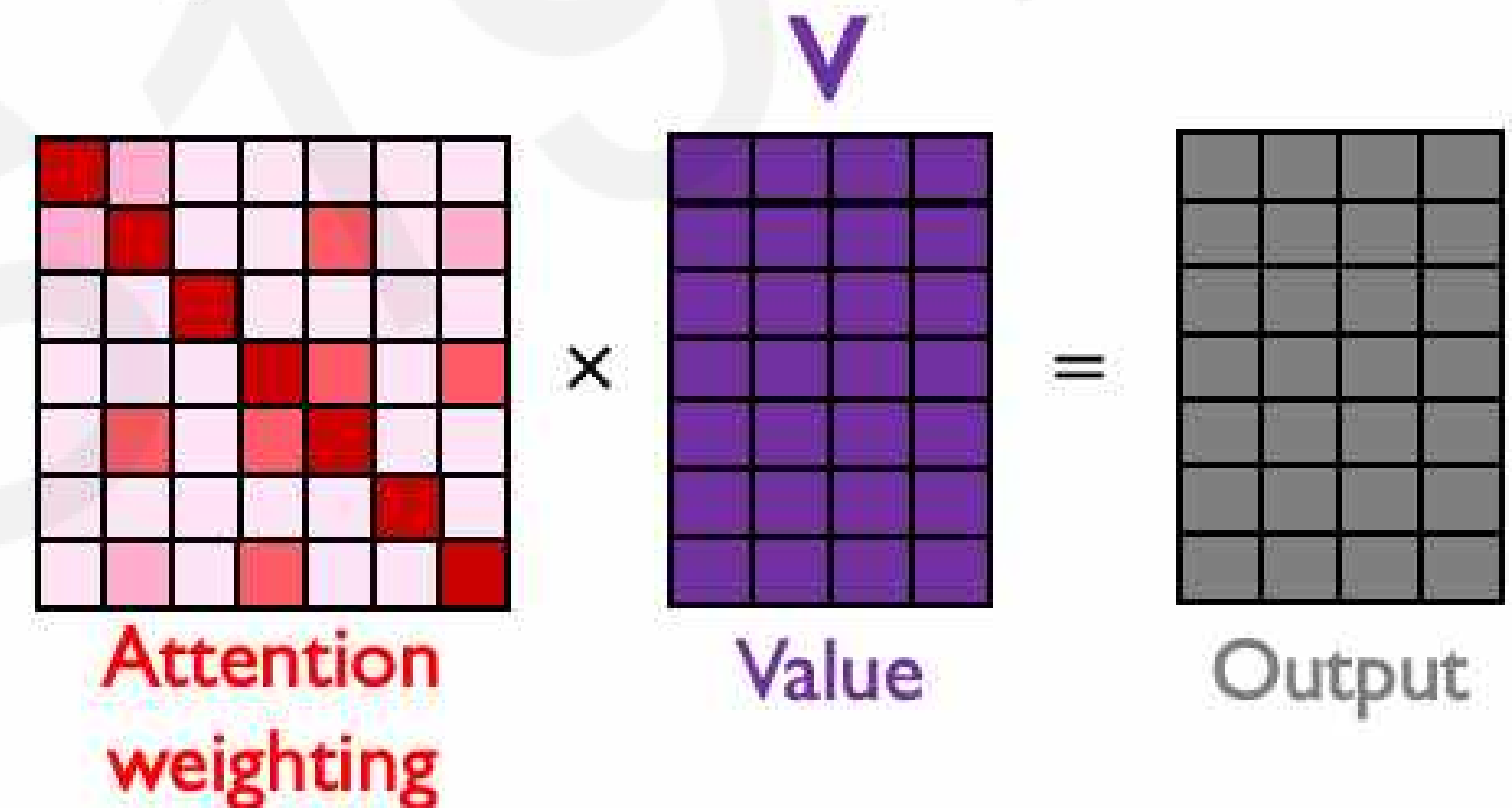

$$\text{softmax} \left(\frac{Q \cdot K^T}{\text{scaling}} \right) \cdot V = A(Q, K, V)$$

Learning Self-Attention with Neural Networks

Goal: identify and attend to most important features in input.

1. Encode **position** information
2. Extract **query, key, value** for search
3. Compute **attention weighting**
4. Extract **features with high attention**

These operations form a self-attention head that can plug into a larger network. Each head attends to a different part of input.

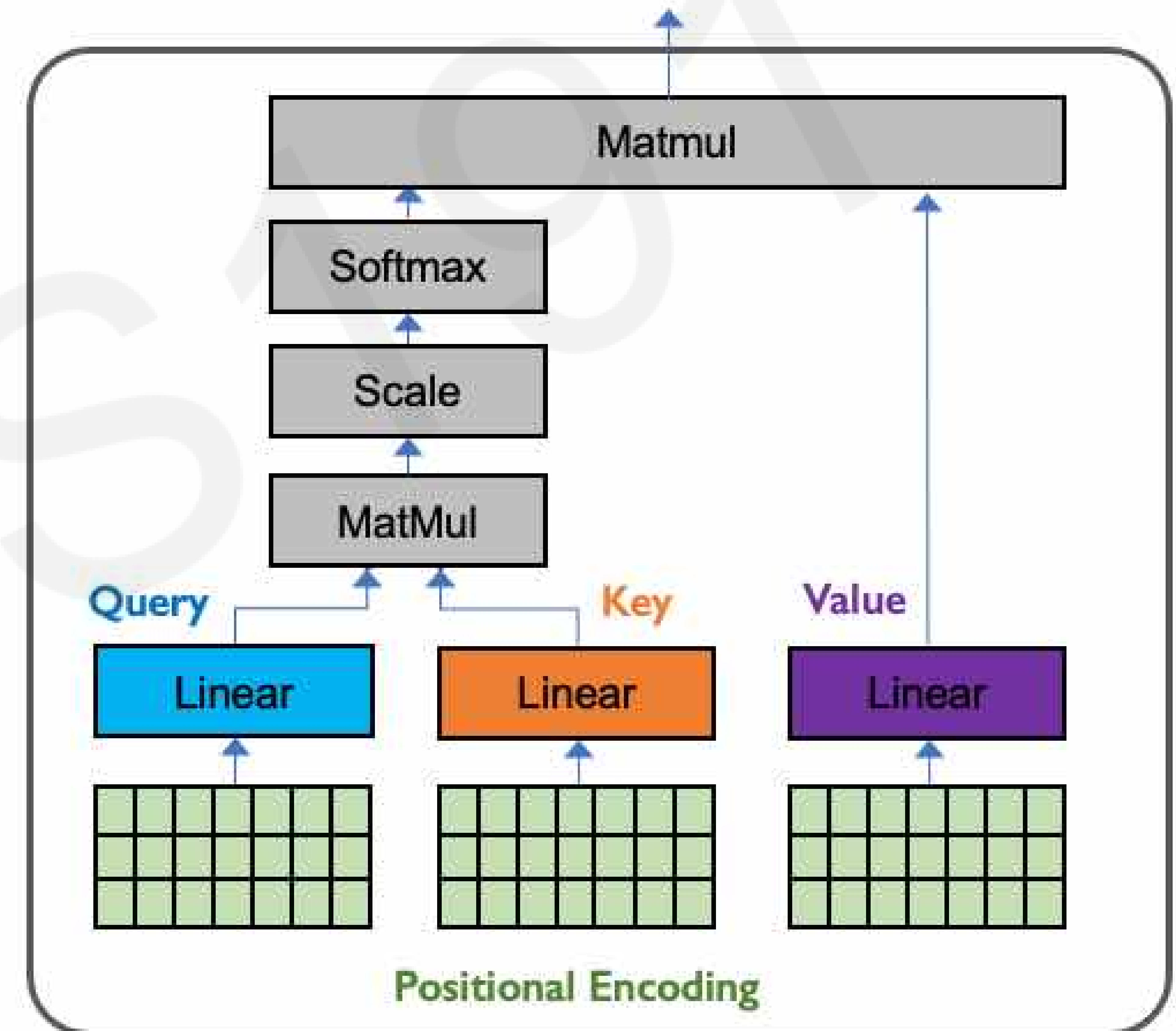

$$\text{softmax} \left(\frac{Q \cdot K^T}{\text{scaling}} \right) \cdot V$$

Applying Multiple Self-Attention Heads



Attention weighting

×



Value

=



Output



Output of attention head 1



Output of attention head 2



Output of attention head 3

Self-Attention Applied

Language Processing



An armchair in the shape of an avocado

BERT, GPT-3

Devlin et al., *NAACL* 2019
Brown et al., *NeurIPS* 2020

Biological Sequences

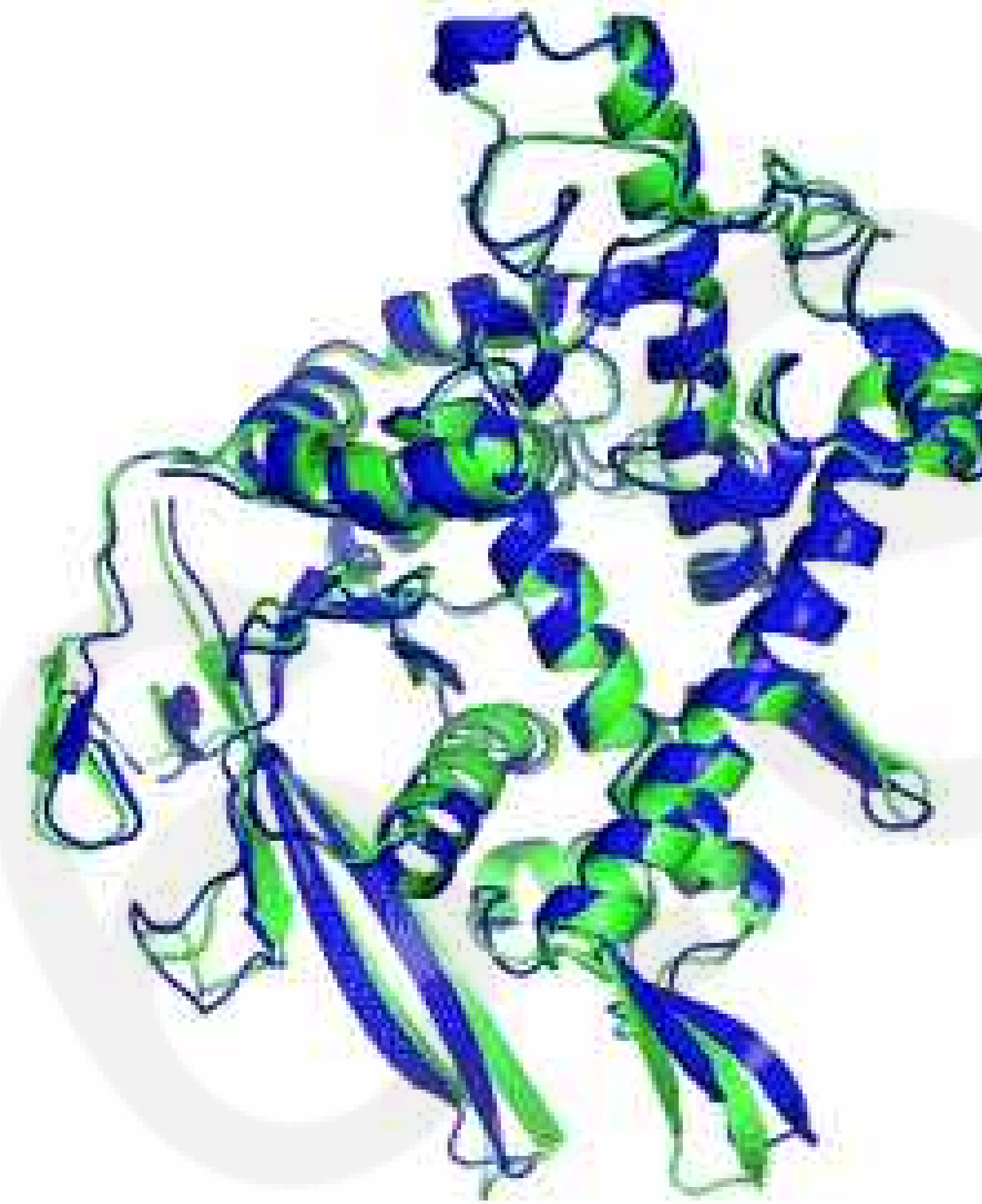

AlphaFold2

Jumper et al., *Nature* 2021

Computer Vision

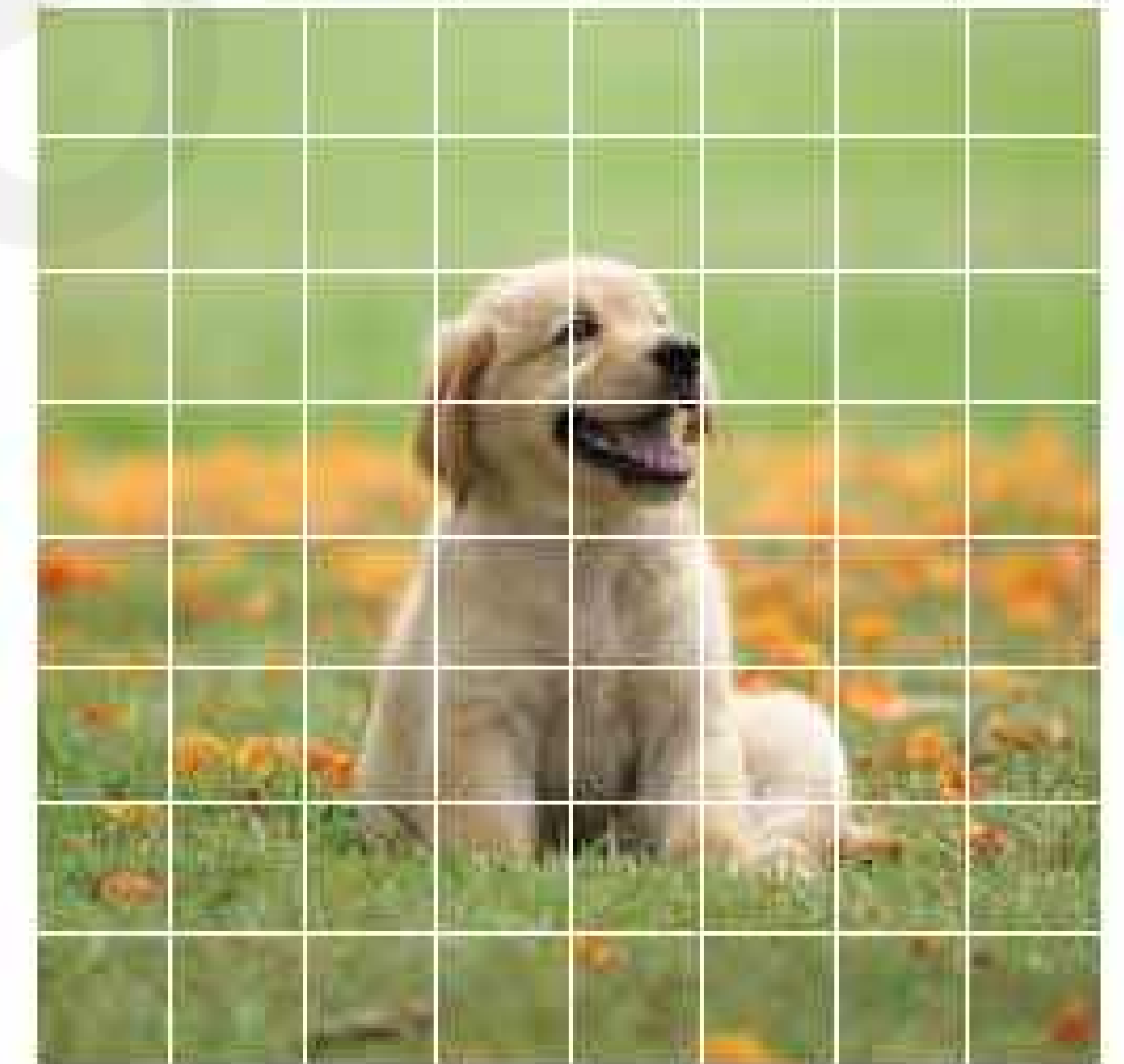

Vision Transformers

Dosovitskiy et al., *ICLR* 2020

Deep Learning for Sequence Modeling: Summary

1. RNNs are well suited for **sequence modeling** tasks
2. Model sequences via a **recurrence relation**
3. Training RNNs with **backpropagation through time**
4. Models for **music generation**, classification, machine translation, and more
5. Self-attention to model **sequences without recurrence**

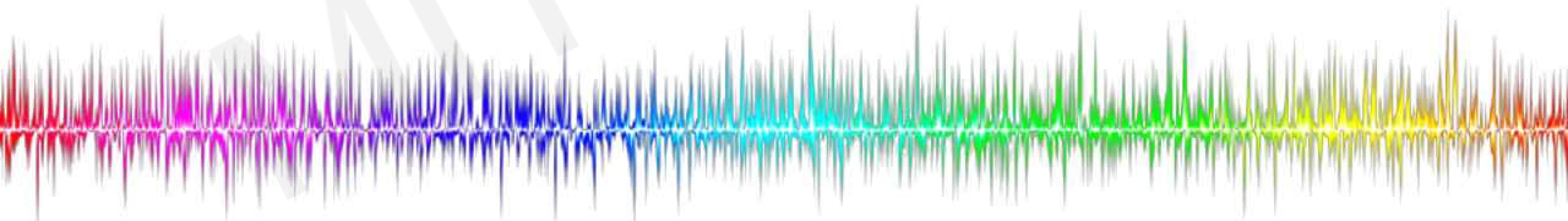

6.S191: Introduction to Deep Learning

Lab 1: Introduction to TensorFlow and Music Generation with RNNs

Link to download labs:

<http://introtodeeplearning.com#schedule>

1. Open the lab in Google Colab
2. Start executing code blocks and filling in the #TODOs
3. Need help? Come to the class Gather.Town!

